

# Mini Monitor Installation, Operation and Maintenance



Made in the  
United States of America



Figure 1. Desco Mini Monitor

## Description

The Desco Mini Monitor is a single workstation continuous monitor. It continuously monitors the path-to-ground integrity of one operator and one ESD worksurface. Its illuminated enclosure makes the status of the operator and worksurface highly visible to the operator and supervisor. Use the Desco 19344 Ring Magnets when mounting the monitor in areas without a worksurface.

The Mini Monitor is designed with Wave Distortion Technology to provide stable continuous monitoring of the path-to-ground and presence of 1 megohm resistance of an operator's wrist strap. Audio and visual alarms activate (in less than 50 milliseconds) when the operator unintentionally disconnects from the monitor or the wrist strap connection points are intermittent. The Mini Monitor also monitors for a worksurface path-to-ground of less than 10 megohms. All Mini Monitors are calibrated to NIST standards.

## WAVE DISTORTION

**Wave Distortion Technology is the Most Reliable Technology for the Continuous Monitoring of Single-Wire (Conductor) Wrist Straps**

"Wave Distortion" or vector impedance works by applying a continuous test voltage of 1.2 volts peak-to-peak at 1 to 2 microamperes (0.000002 amperes) to the wrist strap that is connected to the continuous or constant monitor. The test voltage creates a square wave that the monitor circuit compares to established patterns. By monitoring the "distortions", or shape of the square wave, Wave Distortion Technology determines if the monitored circuit is complete - the operator is in the circuit and the total equivalent DC resistance is within specifications. Wave Distortion Technology produces a very fast alarm time and minimal false alarms.

ANSI/ESD S20.20 section 7.4 states "Compliance verification records shall be established and maintained to provide evidence of conformity to the technical requirements." Per ANSI/ESD S1.1 Annex A.3, "Daily testing may be omitted if continuous monitors are used." Per Handbook ESD TR20.20 section 11.4.4 "Typical test programs recommend that wrist straps that are used daily should be tested daily. However, if the products that are being produced are of such value that knowledge of a continuous, reliable ground is needed, then continuous monitoring should be considered or even required."

The Mini Monitor and its accessories are available as the following item numbers:

Item	Description
<a href="#">19341</a>	Mini Monitor, with North American Power Adapter
<a href="#">19342</a>	Mini Monitor, with Universal Power Adapter
<a href="#">19344</a>	Ring Magnets, 1 Pair
<a href="#">19345</a>	Push & Clinch Snap Kit
<a href="#">98221</a>	Wave Distortion Monitor Verification Tester
<a href="#">19657</a>	Power Adapter, 100-240 VAC Input, 9 VDC 150 mA Output, North America Plug
<a href="#">19658</a>	Power Adapter, 100-240 VAC Input, 9 VDC 3 A Output, IEC C14 Inlet
<a href="#">50545</a>	Power Cord, Europe
<a href="#">50546</a>	Power Cord, UK

## Packaging

### 19341 Mini Monitor

- 1 Mini Monitor
- 2 Countersunk Washer
- 2 Flat Head Screw, 6-32 x 3/8"
- 1 Power Adapter with North American Plug, 9 VDC



Figure 2. Desco 19341 Mini Monitor packaging contents

### 19342 Mini Monitor

- 1 Mini Monitor
- 2 Countersunk Washer
- 2 Flat Head Screw, 6-32 x 3/8"
- 1 Power Adapter with IEC C14 Inlet, 9 VDC



Figure 3. Desco 19342 Mini Monitor packaging contents

## Features and Components

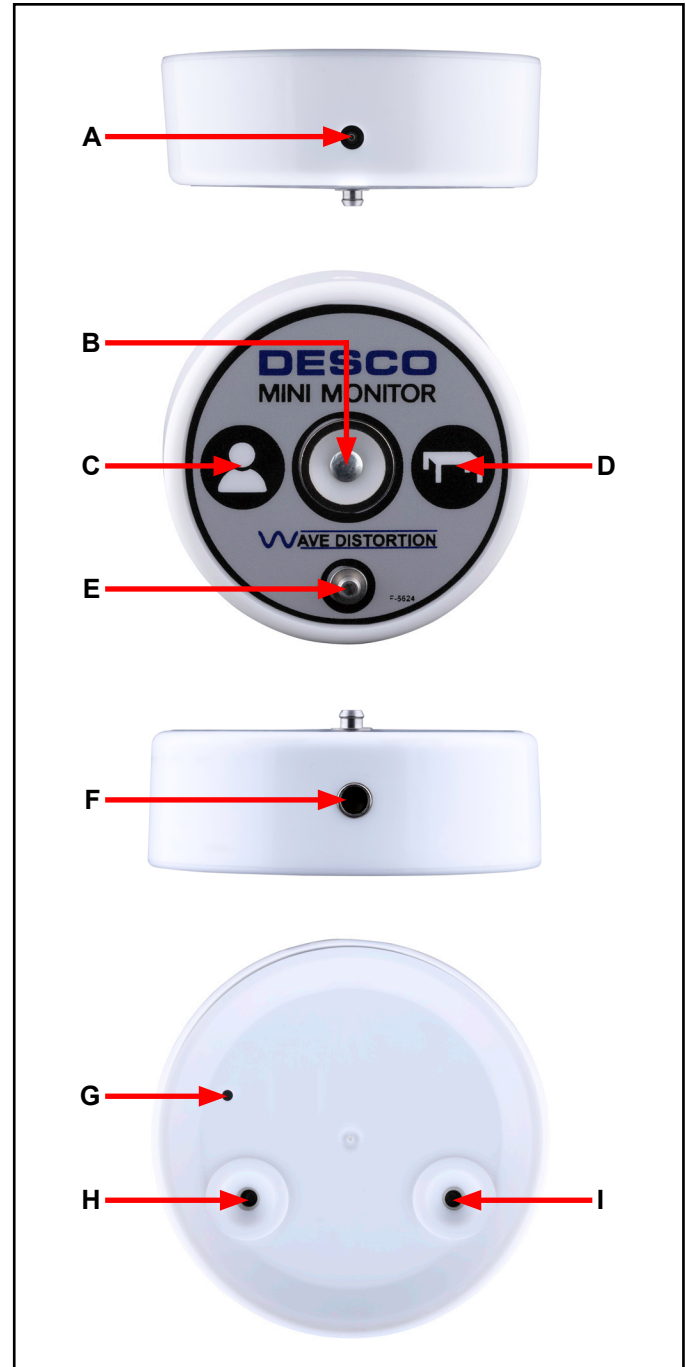

Figure 4. Mini Monitor features and components

- A. Power Jack:** Connect the included 9 VDC power adapter here.
- B. Park Delay Switch:** Allows the operator to disconnect (and park) a wrist strap when leaving the workstation, without creating a false alarm. Touch the ParkSnap™ or park delay switch, and the monitor's audible alarm will disable for approximately 8 seconds. Use this time to disconnect the wrist cord from the wristband, and attach it to the park snap or remove

the banana plug from the jack. Upon returning to the workstation and disconnecting the wrist cord from the park snap, the operator has approximately 8 seconds to reconnect the wrist cord to a worn wristband before activating the alarm. The 8 second timer is indicated by the growing intensity of the monitor's blue LEDs. The blue LEDs will pulse when the operator jack is vacant to indicate standby mode.

**C. Operator LED:** Illuminates green when the operator is properly grounded. Illuminates solid red and audible alarm sounds when the operator is not properly grounded.

**D. Worksurface LED:** Illuminates green when the worksurface is properly grounded. Illuminates red and audible alarm sounds when the worksurface is not properly grounded.

**E. ParkSnap™:** Allows the operator to disconnect (and park) a wrist strap when leaving the workstation, without creating a false alarm. Touch the ParkSnap™ or park delay switch, and the monitor's audible alarm will disable for approximately 8 seconds. Use this time to disconnect the wrist cord from the wristband, and attach it to the ParkSnap™ or remove the banana plug from the jack. Upon returning to the workstation and disconnecting the wrist cord from the ParkSnap™, the operator has approximately 8 seconds to reconnect the wrist cord to a worn wristband before activating the alarm.

**F. Monitored Operator Jack:** Insert the single-wire wrist cord here to monitor the operator's connection to ground.

**G. Set Switch:** Toggles the monitor's settings for the audible alarm and mat monitor circuit.

Function	Procedure
Audible Alarm Volume	<ol style="list-style-type: none"> <li>1. Push and release the switch to toggle the buzzer's volume.</li> <li>2. The volume will toggle from low and high settings.</li> </ol>
Enable / Disable Worksurface Monitor Circuit	<ol style="list-style-type: none"> <li>1. Push and hold the switch until all LEDs illuminate white.</li> <li>2. Release the switch.</li> <li>3. An illuminated Worksurface LED indicates that the worksurface monitor circuit is enabled. A non-illuminated Worksurface LED indicates that the worksurface monitor circuit is disabled.</li> </ol>

**H. Threaded Ground Terminal:** Connects the worksurface mat to electrical ground.

**I. Threaded Worksurface Monitor Terminal:** Verifies that the worksurface's path-to-ground is less than 10 megohms.

## Installation

1. Remove the Mini Monitor from the carton, and inspect for damage.
2. Locate an appropriate AC outlet near the Mini Monitor, and test it for proper wiring and grounding prior to use. The Desco AC Outlet Analyzer or similar test equipment may be used to verify the outlet's functionality. Use item [98133](#) for 120 VAC North American outlets and item [98134](#) for 220 VAC UK outlets.
3. Determine the mounting location of the Mini Monitor. It is normally installed toward the front edge of a workstation. Use a blade to pierce two holes 1-5/16" apart from one another into the worksurface mat. [Click here](#) to download the mounting template.
4. Use a Phillips screwdriver to secure the two flathead screws and countersunk washers through the worksurface mat and into the two threaded terminals on the bottom of the monitor.

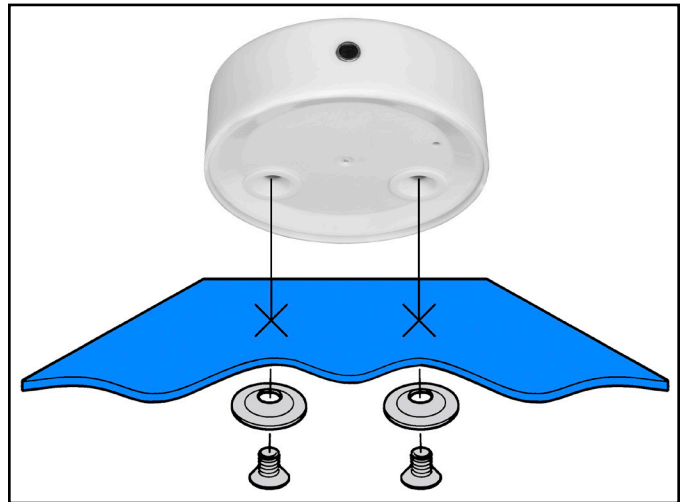

Figure 5. Securing the Mini Monitor to a worksurface mat

5. Connect the power adapter to the power jack located on the Mini Monitor. Plug the power adapter into the tested AC outlet.

### 19344 Ring Magnets

Use the Desco 19344 Ring Magnets to mount the Mini Monitor onto metallic surfaces when worksurface mats are not used.

1. The worksurface monitor circuit must first be disabled before installing the magnets. Supply power to the monitor, and use a probe to push and hold the set switch on the bottom side until the LEDs illuminate white. The worksurface LED on the top side will turn off upon release of the set switch.

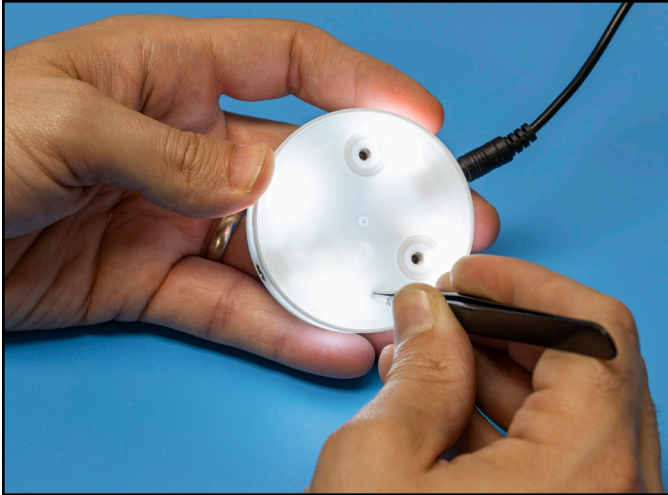

Figure 6. Using the set switch to disable the worksurface monitor circuit

2. Use the included flat head screws to install the two ring magnets to the bottom side of the monitor.

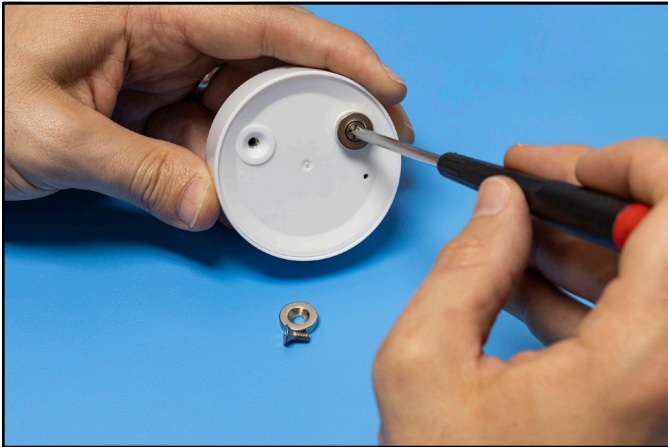

Figure 7. Installing the Desco 19344 Ring Magnets

3. Use the ring magnets to mount the monitor onto a metallic surface.

### 19345 Push & Clinch Snap Kit

Use the Desco 19345 Push & Clinch Snap Kit to connect the Mini Monitor to worksurface mats with a thin conductive layer. The prongs of the push & clinch snaps increase the electrical contact area with worksurface mats that use a thin conductive layer/ground plane. The kit includes two 10 mm studs, two 6-32 x 3/8" flat head screws, and two 10 mm socket push & clinch snaps.

1. Secure the two 10 mm studs to the bottom of the Mini Monitor using the two flat head screws.
2. Attach the two push & clinch snaps onto the two studs on the bottom of the Mini Monitor.



Figure 7. Installing the Desco 19345 Push & Clinch Snap Kit

3. Determine a location on the worksurface mat to mount the Mini Monitor.
4. Press the Mini Monitor with the push & clinch snaps onto the mat until the prongs pierce through the material.
5. Fold the prongs over to secure the snaps onto the mat.

## Operation

1. Fit the wristband snugly onto the wrist.
2. Snap the wrist cord to the wristband.
3. Plug the wrist cord into the operator jack. The operator LED will illuminate green. This indicates that the operator is properly grounded.
4. If this does not happen, examine the wrist cord for continuity or damage and the wristband to ensure that it fits securely. If experiencing dry skin, the operator may apply an approved dissipative hand lotion such as [MENDA Reztore® ESD Hand Lotion](#).
5. When leaving the workstation, first touch the monitor's park switch or park snap. The monitor's audible alarm will disable for approximately 8 seconds. Use this time to disconnect the wrist cord from the wristband and attach it to the park snap without sounding a false alarm.
6. Upon returning to the workstation and disconnecting the wrist cord from the park snap, the monitor will provide approximately 8 seconds for the operator to reconnect the wrist cord to a worn wristband before sounding the monitor's alarm.



Figure 9. Illuminating green to indicate a proper operator path-to-ground



Figure 10. Illuminating red to indicate a broken operator path-to-ground

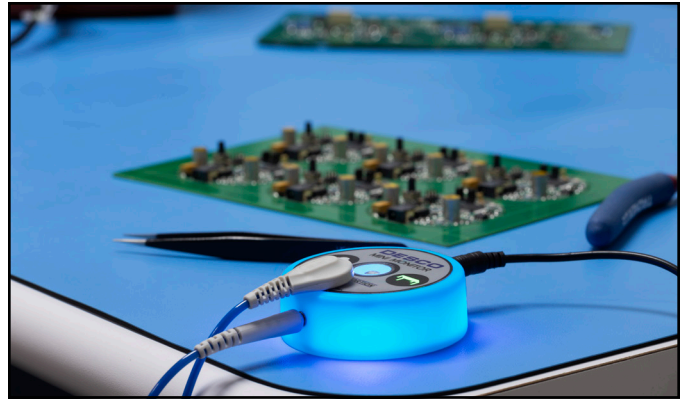

Figure 11. Illuminating blue to indicate standby condition

## Calibration

Frequency of recalibration should be based on the critical nature of those ESD sensitive items handled and the risk of failure for the ESD protective equipment and materials. In general, Desco recommends that calibration be performed annually.

Use the Desco 98221 Wave Distortion Monitor Verification Tester to perform periodic verification (once every 6-12 months) of the Mini Monitor. The verification tester can be used to check the test limits of the Mini Monitor without removing it from the workstation.

See [TB-3074](#) for more information.



Figure 12. Desco 98221 Wave Distortion Monitor Verification Tester

## Specifications

Input Voltage and Frequency (External Adapter)	AC/DC Power Adapter Power Input: 100-240 VAC, 50/60 Hz Power Output: 9 VDC Cable Length: 5 ft. (1.5 m)
Operating Temperature	50 to 95° F (10 to 35° C)
Environmental Requirements	Indoor use only at altitudes less than 6500 ft. (2 km) Maximum relative humidity of 80% up to 85° F (30° C) decreasing linearly to 50% @ 85° F (30° C)
Dimensions	2.49" Dia. x 0.84" H (63 mm Dia. x 21 mm H)
Weight	1.6 oz. (44 g)
Operator Test Range*	500 kilohms to 10 megohms impedance
Worksurface Test Limit**	10 megohms (±20%)
Operator Test Voltage	1.2 V peak-to-peak @ 1.2 µA, open circuit
Worksurface Test Voltage	5 to 7.5 V, open circuit
Alarm Response Time	<50 ms
U.S. Patent No.	Pending
Country of Origin	United States of America

\*This cannot be verified with standard DC test equipment. The continuous monitor is an impedance sensing device, and the limits are determined by the magnitude and angle of the impedance.

\*\*The worksurface mat must have a conductive layer such as Dual Layer Rubber or Dissipative 3-Layer Vinyl with conductive buried layers. Desco workstation monitors are not recommended for use with homogeneous matting.

ANSI/ESD S20.20 requires the use of a surface resistance meter for periodic verification of a worksurface's resistance-to-ground (Rtg). Constant monitors may not be used as a substitute for this requirement.

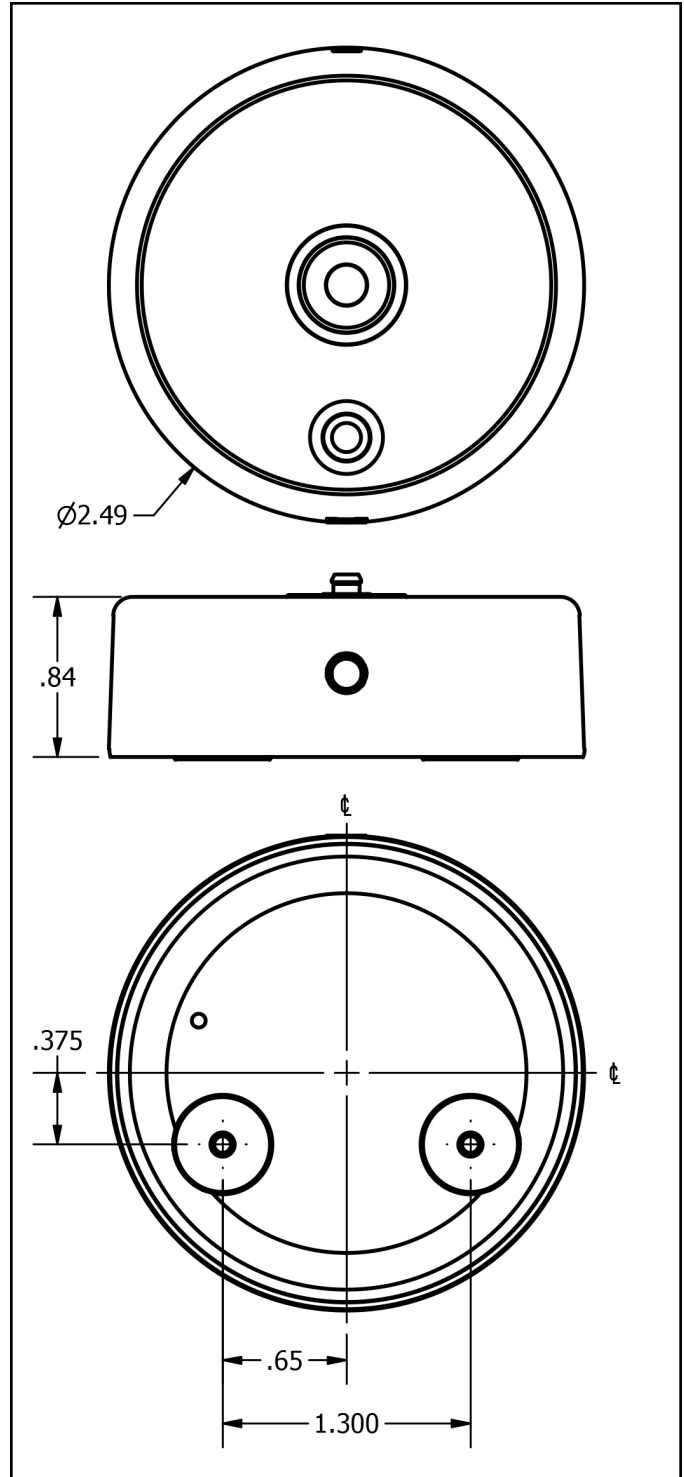

Figure 13. General dimensions in inches. [Click here](#) to download the mounting template.

### Limited Warranty, Warranty Exclusions, Limit of Liability and RMA Request Instructions

See the Desco Warranty - [Desco.com/Limited-Warranty.aspx](https://Desco.com/Limited-Warranty.aspx)