

# 975 Ionized Air Blower Installation, Operation, and Maintenance



Made in Japan



Figure 1. SCS 975 Ionized Air Blower

## Description

The SCS 975 Ionized Air Blower is used for neutralizing electrostatic charges on insulators and ungrounded conductors. Its fast discharge times (< 1 second at 12 inches) and ±10 volt offset voltage exceed the required limits of ANSI/ESD S20.20 and ESD TR53. The 975 Ionized Air Blower monitors its offset voltage (balance), and it alarms when emitter cleaning is required. A built-in automatic emitter point cleaner periodically brushes away dust and minimizes maintenance. The emitters may be accessed for thorough cleaning with the use of a single thumb screw. The 975 Ionized Air Blower features a powder coated steel enclosure, multi-mount stand, and terminal block with alarm output for machine integration.

The SCS 975 Ionized Air Blower operates on Steady-state DC. Steady-state DC systems consist of separate negative and positive ion emitters connected by a pair of high-voltage cables to their respective high-voltage power supplies. DC power is constantly applied to the emitter points. The ionizer utilizes sampling from its inner fan grill to continuously adjust the output and maintain its offset voltage.

“The primary method of static charge control is direct connection to ground for conductors, static dissipative materials, and personnel. A complete static control program must also deal with isolated conductors that cannot be grounded, insulating materials (e.g., most common plastics), and moving personnel who cannot use wrist or heel straps or ESD control flooring and footwear. Air ionization is not a replacement for grounding methods. It is one component of a complete static control program. Ionizers are used when it is not possible to properly ground everything and as backup to other static control methods. In clean rooms, air ionization may be one of the few methods of static control available.” [ESD Handbook ESD TR20.20 Ionization, section 5.3.6.1 Introduction and Purpose / General Information]

The 975 Ionized Air Blower and its accessories are available as the following item numbers:

Item	Description
<a href="#">975A</a>	Ionized Air Blower with North America Power Adapter
<a href="#">975N</a>	Ionized Air Blower without Power Adapter
<a href="#">975P</a>	North America Power Adapter

## Packaging

- 1 Ionized Air Blower
- 1 Ground Wire
- 1 Power Adapter (975A only)
- 1 North America Power Cord (975A only)
- 1 Certificate of Calibration

# Features and Components

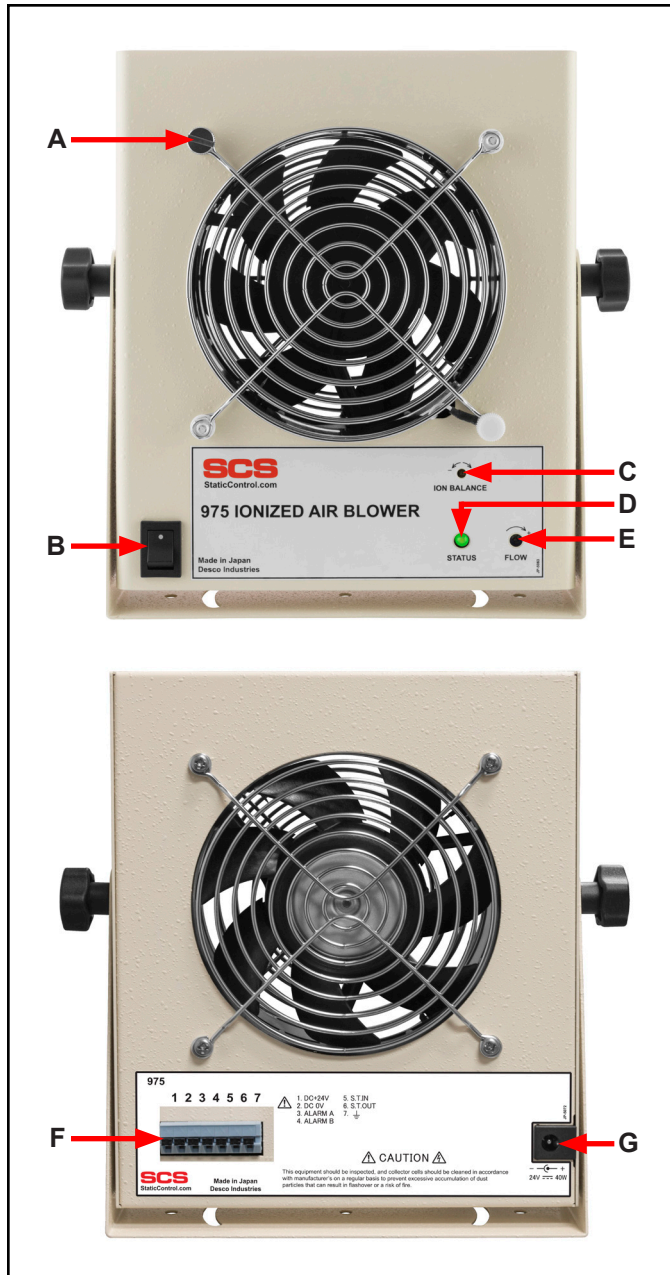

Figure 2. 975 Ionized Air Blower features and components

- A. Fan Grill Thumb Screw:** Loosens the fan grill, so it may be swung to the side and grant access to the emitter points for cleaning.
- B. Power Switch:** Powers the ionizer ON and OFF.
- C. Ion Balance Dial:** Use a flat-blade screwdriver to rotate the dial clockwise to change the ion balance in the positive direction and counterclockwise to change the ion balance in the negative direction.

**D. Status LED:** Provides 6 different indications. See the table below.

Indicator	Status
Green	Normal operation
Blinking orange once per 1.6 seconds	Maintenance needed or ion balance dial is not set to 0V
Blinking red once per 1.6 seconds	Fan does not rotate
Blinking red twice per 1.6 seconds	High-voltage module failure
Blinking red three times per 1.6 seconds	Ion balance out of control
Blinking red four times per 1.6 seconds	Drive failure in emitter point cleaner

- E. Fan Speed Dial:** Use a Phillips-head screwdriver to rotate the dial clockwise to increase the fan speed or counterclockwise to decrease the fan speed.
- F. Terminal Block:** Wires to external power provided by a machine and outputs an alarm signal. See "Terminal Block Setup" on page 3 for more information.
- G. Power Inlet:** Connect the included power adapter here.

## Installation

### Hardware Setup

Install the included ground wire to Terminal 7 at the back of the ionizer. Connect the opposite end of the wire to equipment ground. Place the 975 Ionized Air Blower at a desired location where the airflow will not be restricted. Ensure a space of at least 4 inches (10 cm) at the rear and on both sides of the ionizer to provide sufficient airflow. Use the tilt lock knobs to aim the ionizer at the area to be neutralized. Ensure that the power switch is set to OFF. Connect the ionizer's power cord into an appropriate AC power source.

Note that placement of the ionizer is important in determining its effectiveness. The distance from the targeted object and fan speed affect the ionizer's performance. The discharge time will increase as the distance increases or fan speed is reduced.

## Terminal Block Setup

Use insulated wires in 18-24 AWG size for wiring to the terminal block.

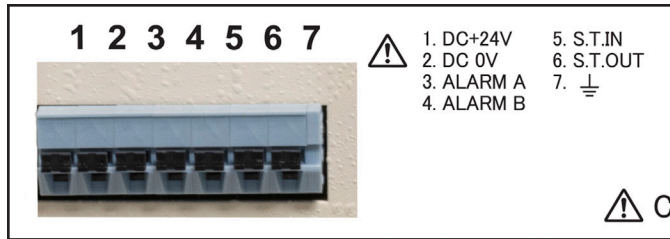

Figure 3. Terminal block

Terminals 1 and 2 are for power input from a 24 VDC supply when not using the included power adapter.

Terminals 3 and 4 are for alarm output. They are used for open collector output (up to 30 V and 100 mA). Current flows between terminals 3 and 4 (GND) on the terminal block when an alarm is output.

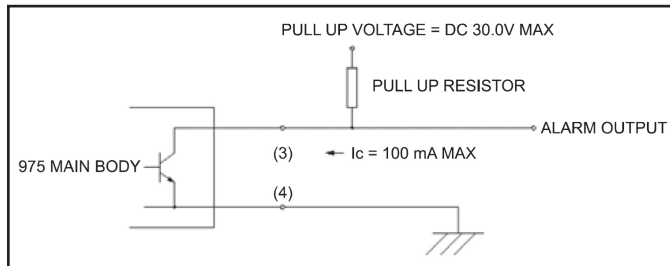

Figure 4. Alarm open collector wiring diagram

Terminals 5 and 6 control the timing of the emitter point cleaner. When multiple units are fed from the same power supply, the rated power of the supply may become insufficient if cleaning occurs simultaneously.

To avoid this situation:

- Prepare a power supply that can provide the total power needed for simultaneous cleaning. Terminals 5 and 6 are not used in this case.
- Make connections between the terminal blocks on multiple units to avoid a peak of power consumption at one time by allowing cleaning to occur in sequence. See below.

Connect the ionizers as shown below. This will make Unit I work as a master and Units II, III, and IV as slaves so that the four sets of emitter points are cleaned one after the other.

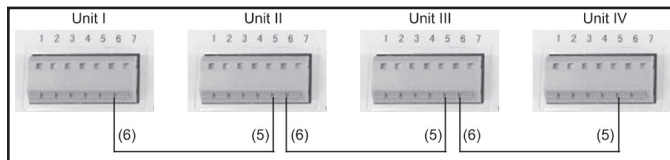

Figure 5. Wiring terminals 5 and 6 to multiple ionizers

Terminal 7 is for grounding the ionizer. Grounding is required for optimal performance of the ionizer.

## Operation

1. Position the ionizer so that maximum airflow is directed towards the items or area to be neutralized.
2. Rock the power switch to the ON position. The status LED will illuminate green during normal operation.
3. Set the fan speed dial to the desired setting. Higher airflow will result in faster discharge times.



Figure 6. Using the 975 Ionized Air Blower on a workbench



Figure 7. Using the 975 Ionized Air Blower at a machine station

## Maintenance

Occasional cleaning of the case and of the ionizing electrodes are the only routine maintenance procedures required.

### Cleaning the Enclosure

Wipe the enclosure with a soft cloth moistened with water. If a stronger cleaning solution is required, mild soap with water may be used. The use of any other cleaning solutions is not recommended.

### Cleaning the Emitter Points

**CAUTION:** Disconnect the power to the ionizer whenever cleaning the emitter points.

When the emitter points become dirty, the internal circuitry of the ionizer will be automatically adjusted to emit an equal amount of positive and negative ions. The automated brushes will keep the emitter points clean by brushing them 8 times per cleaning cycle. The cycle runs hourly. Particulates on the emitter point may, however, inhibit ionization to a limited degree. The emitter points are located behind the front grills. A jet of clean, compressed air can be used to remove dirt on emitter points. If a more rigorous cleaning method is needed to remove particulate, clean the points with a cotton swab dampened with isopropyl alcohol. Access to the points is available through the front grill. Loosen the thumb screw to disconnect the fan grill and swing it to the side. Be careful not to damage the points during cleaning.



Figure 8. Loosening the fan grill thumbscrew



Figure 9. Swinging the front fan grills to access the emitter points inside the ionizer



Figure 10. Accessing the emitter points

## Calibration

The SCS 975 Ionized Air Blower is factory adjusted to provide optimum performance. Further adjustment in the field is not possible. However, the following instructions can be followed to determine whether the Ionizer is performing to specifications. The testing follows the procedure outlined in the standard for Ionization, ANSI/ESD STM3.1. Please refer to this standard for more complete information.

Frequency of recalibration should be based on the critical nature of those ESD sensitive items handled and the risk of failure for the ESD protective equipment and materials. In general, SCS recommends that calibration be performed annually.

Periodically measure the balance and neutralization times of the ionizer to verify that it is performing within specifications. These measurements should be taken using a charged plate monitor. Calibration should be performed in accordance with the ESD Association ionization standard ANSI/ESD STM3.1. With the ionizer positioned a distance of 12 inches (30 cm), the neutralization (discharge) time of  $\pm 1000V$  to  $\pm 100V$  should be less than 1.5 seconds, and the balance should be  $\pm 10V$  or better.

## Neutralization (Discharge) Times

The comparative efficiency of bench top ionizers is determined by a standard test published by the ESD Association: ANSI/ESD STM3.1. Typical positive and negative decay times ( $\pm 1000V$  to  $\pm 100V$ ) measured using this standard are shown in Figure 11.

NOTE: All discharge times are in seconds and representative only. They are not a guarantee. The discharge times were recorded in a factory ambient environment.

## Specifications

Input Voltage and Frequency (External Adapter)	Power Input: 100-240 VAC, 50/60 Hz Power Output: 24 VDC, 2.7 A Power Adapter Cable Length: 5.0' (1.5 m) Power Cord Length: 6' (1.8 m)
Operating Environment	50° to 104° F (10° to 40° C) 20 to 70% R.H.
Neutralization (Discharge) Time at 12"	< 1 second
Offset Voltage (Balance) at 12"	$\pm 10$ V typical
Ion Emission	Steady-state DC
Airflow	128 CFM max. (3.63 m <sup>3</sup> /min)
Ozone	<0.05 ppm
Power Consumption	20 W
Emitter Points	Tungsten
Dimensions (without stand)	7.9" H x 6.7" W x 2.8" D (200 mm x 170 mm x 72 mm)
Weight	3.2 lbs (1.5 kg)
Country of Origin	Japan

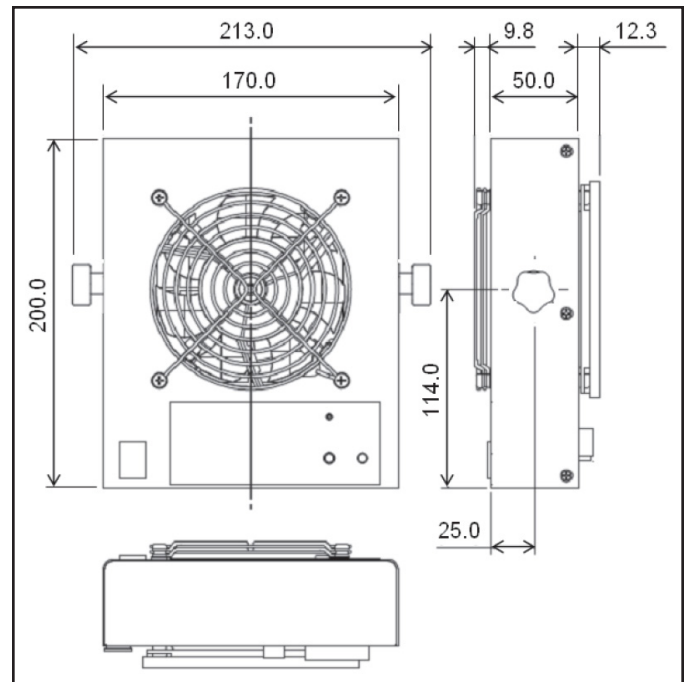

Figure 11. General dimensions of the 975 Ionized Air Blower (mm)

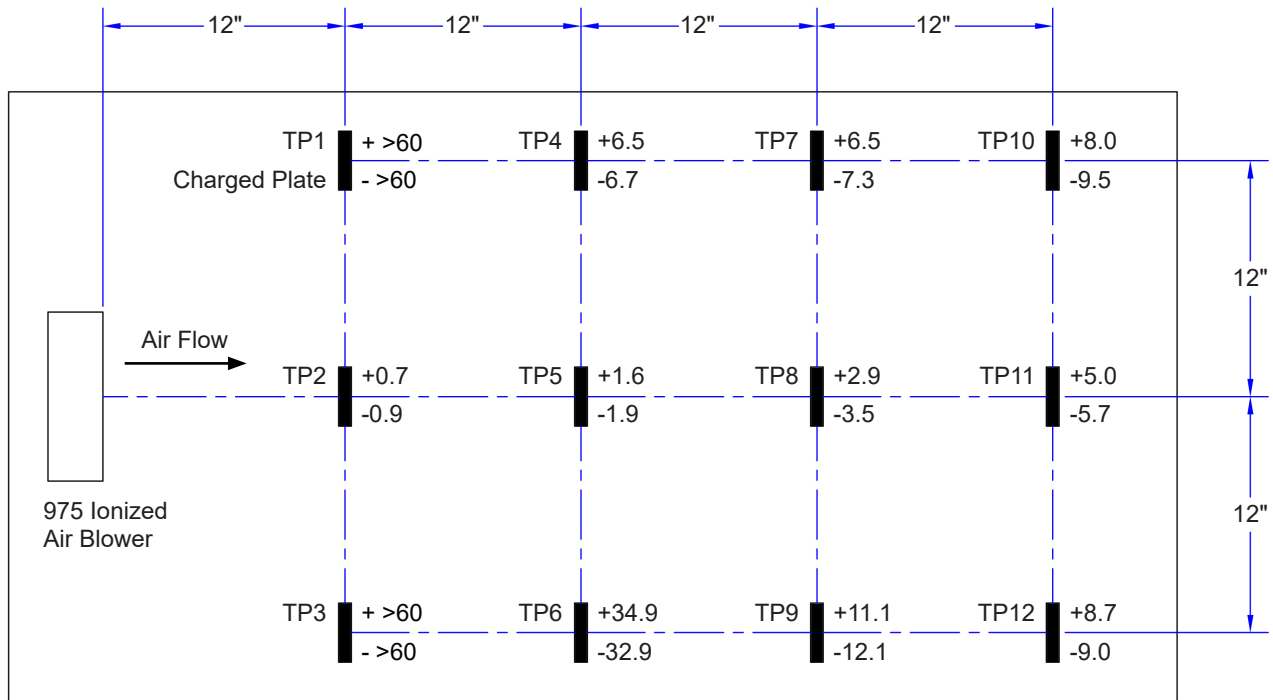

Figure 11. Neutralization (discharge) times in seconds

**Limited Warranty, Warranty Exclusions, Limit of Liability and RMA Request Instructions**

See the Desco Asia Warranty - [DescoAsia.com/Limited-Warranty.aspx](http://DescoAsia.com/Limited-Warranty.aspx)