

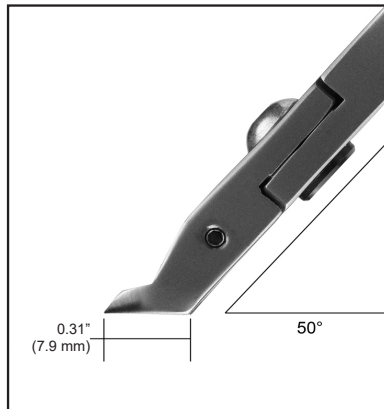

**Features:**

- **Application:** Cutting edges at an angle to the board are preferred when access to the object being cut is very limited or when the work area is very crowded. 5072 features a robust, large cutting head that is excellent for cutting several leads in a single cut.
- **Head Shape:** Angulated 50° Large, Long Oval Head
- **Material:** Carbon Steel
- **Material Hardness:** 62-63 HRC
- **Handle Grips:** Cushion Double Sheathed, ESD Safe
- **RTT Resistance:**  $<1 \times 10^{11}$  ohms tested per ANSI/ESD STM11.13 Two-Point Probe, resistance measurement for static dissipative materials

Item	Cutting Edge	Cutting Capacity (Soft Copper Wire)	Angle	Handle Length	Overall Length
5072	Flush	.008 in - .039 in 0.2 mm - 1 mm 32 - 18 AWG	50°	Standard	4.8 in 123 mm

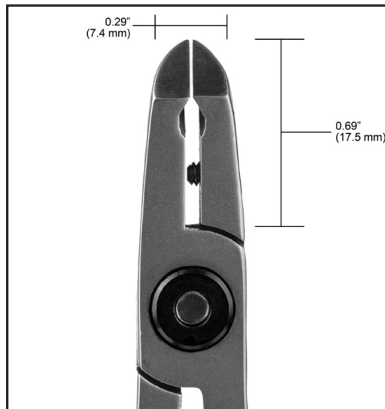

Unless otherwise noted, tolerance is  $\pm 10\%$ .

Specifications and procedures subject to change without notice.

**LARGE ANGULATED 50° OVAL FLUSH CUTTER, STANDARD HANDLE**

**TRONEX**

2860 CORDELIA RD, STE 230, FAIRFIELD, CA 94534  
 PHONE: (909) 627-2453  
 WEBSITE: [TronexTools.com](http://TronexTools.com)

**DRAWING NUMBER**  
5072

**DATE**  
May 2021