

- A. Dual banana jacks for grounding two wrist straps (0.162" - 0.164" ± 0.002" ID).
- B. Black anodized aluminum angle bracket frame, mounts underneath worksurface.
- C. Dual 0.155" (4mm) studs for "parking" wrist strap ground cords when not in use.
- D. 10' ground wire. Insulator: PVC, yellow striped green, 0.100" OD. Conductor: 105 strands each. Approximately 22 gauge with a #10 (0.200" ID) ring terminal.
- E. Slotted bracket allows easy installation for screws with a maximum diameter of 0.175" (4.4mm).
- F. Grounding symbol markings on each banana jack.
- G. Extra #10 (0.200" ID) ring terminal for custom installation.
- H. Vinyl boot insulates electrical circuits.

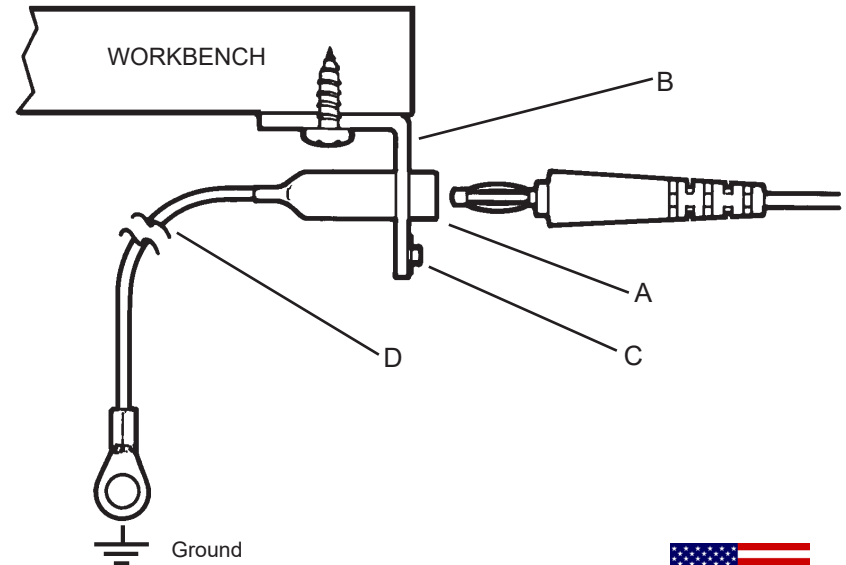
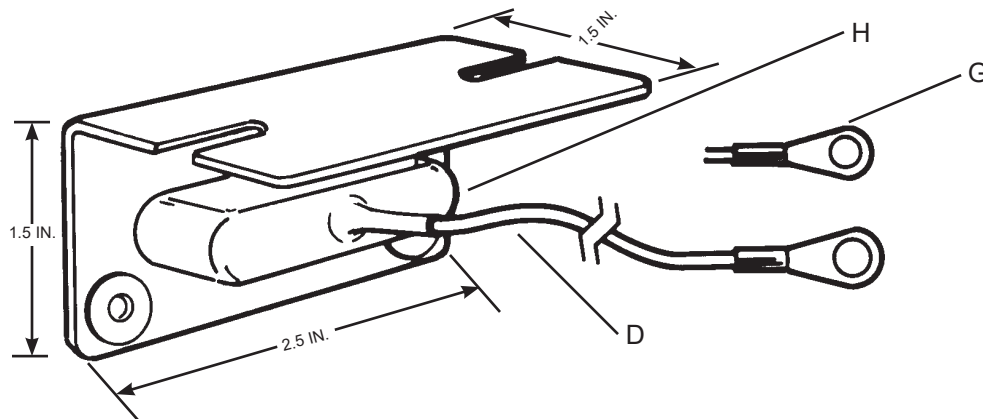
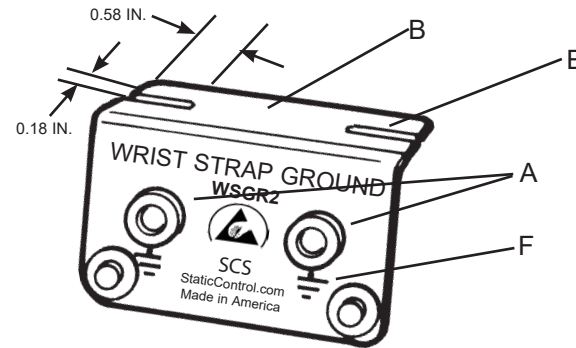

"Grounding / Equipotential Bonding Systems shall be used to ensure that ESDS items, personnel and any other conductors (e.g., mobile equipment) are at the same electrical potential."... "All personnel shall be bonded or electrically connected to the grounding / equipotential bonding system when handling ESDS [ESD sensitive] items." (ANSI/ESDS20.20 section 8.)

"When personnel are seated at ESD protective workstations, they shall be connected to the grounding / equipotential bonding system via a wrist strap system." (ANSI/ESDS20.20-2007 section 8.2)

Specifications and procedures subject to change without notice.



Made in the United States of America

GROUND CORD, DUAL WRIST STRAP, BENCH MOUNT



926 JR Industrial Drive, Sanford, NC 27332
 WEB SITE: StaticControl.com
 PHONE: EAST: (919) 718-0000 | WEST: (909) 627-9634

**DRAWING
 NUMBER**
 WSGR2

DATE:
 August
 2019