



A Donaldson Company

A WORLD LEADER IN FUME EXTRACTION TECHNOLOGY

# Mobile FumeKART

MECHANICAL ENGINEERING

Last Updated on 04.02.2022



Multi purpose mobile dust and fume extraction system for a wide range of applications.

The BOFA FumeKART is the ideal portable air extraction and filtration unit and can be applied to a variety of applications.

Designed to filter dust particles, mould spores, solvent vapours and other pollutants from the work environment, the FumeKART is easy to operate and maintain and provides the additional benefit of being fully portable.

The FumeKART mobile fume extractor provides users with flexibility and the assurance of high-performance filtration. A filter condition indicator is included as a standard feature, together with three-stage filtration: pre-filter, HEPA and gas filter.

Ideal for laser applications, hand soldering, jewellery manufacturing, laser hair removal and lots more...

## Technology



DeepPleat pre-filter



HEPA filter



Advanced carbon filter technology



Multi voltage sensing unit



ProTECT service plan



SureCHECK quality standard

## Key features of the Mobile FumeKART

**Three stage filtration - F8 pre-filter / HEPA / gas filter**  
Standard

**Low noise level**  
Standard

**VOC Sensing (Volatile Organic Compound)**  
Optional

**Complete with filter condition indicator**  
Standard

**Digital air flow control**  
Standard

**Various arm / hood options**  
Optional

Contact BOFA at <https://bofainternational.com/en/contact/>  
<https://bofainternational.com/en/portal/datasheets/mobile-fumekart/>



Approvals: REACH and RoHS. See individual product technical data for specific accreditations

## Technical specification

- 1. Unit / filter condition display
- 2. On / off switch
- 3. Extractor arm - 75/100mm
- 4. Power cable inlet
- 5. Filter housing latch
- 6. Hose inlet connection
- 7. Exhaust outlet
- 8. Handle
- 9. Castors

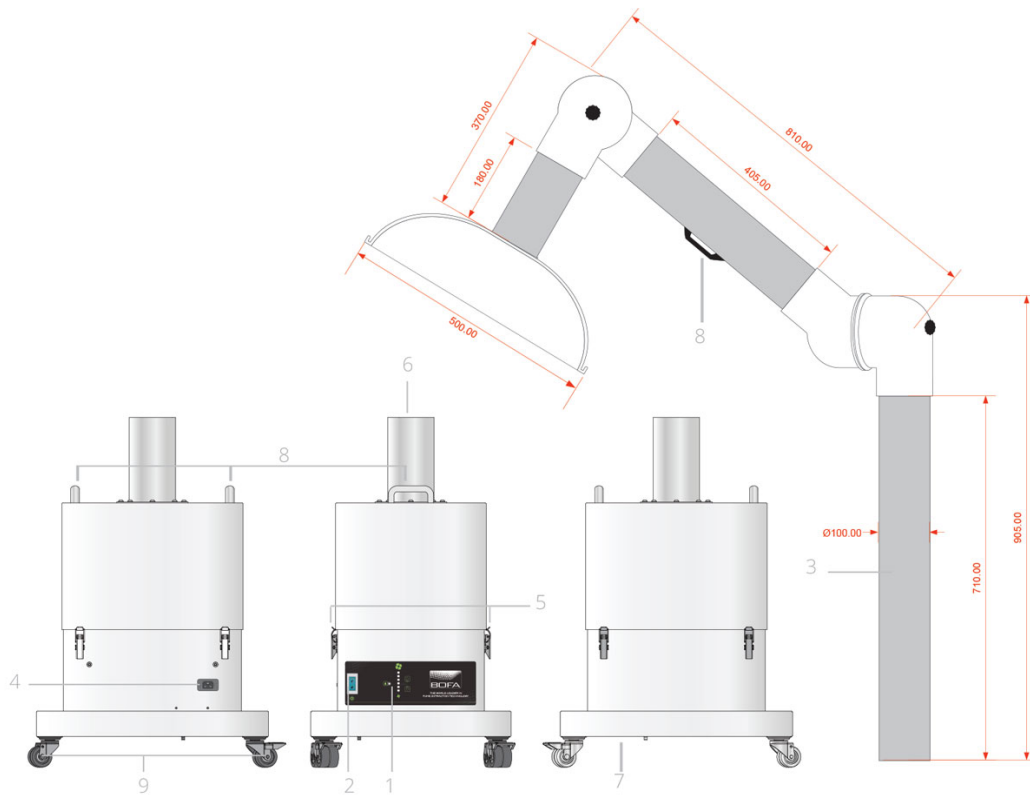

## Airflow through filters

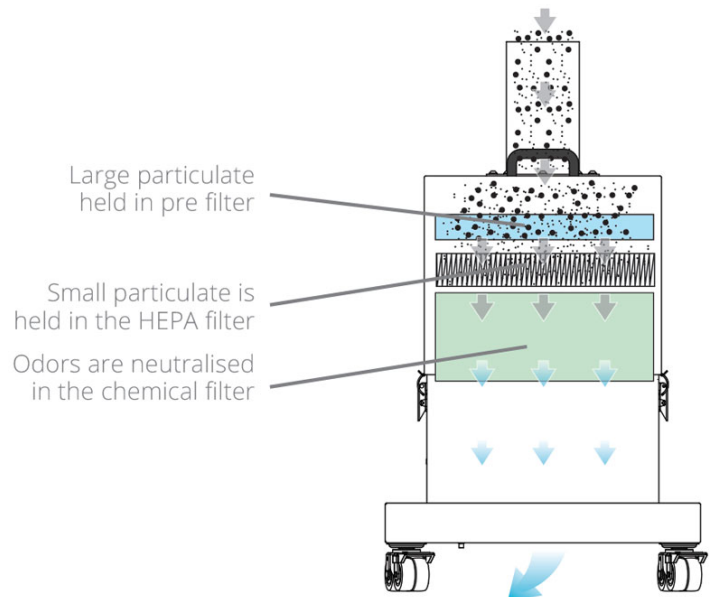
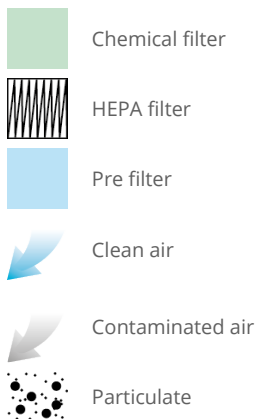

## Technical data

	CE	US
Dimensions (HxWxD)	840 x 475 x 550mm (without arm / spigot)	33.07 x 18.70 x 21.65"
Cabinet construction	Powder coated mild steel	Powder coated mild steel

## Technical data

Blower	Centrifugal turbine	Centrifugal turbine
Airflow	380m <sup>3</sup> /hr	223cfm
Electronics	90 - 257v Single-phase 1~ 50/60Hz Full load current: 12.5 amps	90 - 257v Single-phase 1~ 50/60Hz Full load current: 12.5 amps
Noise level	< 64dBA (at typical operating speed)	< 64dBA (at typical operating speed)
Weight	54kg	119lbs
Approvals	UKCA and CE	UKCA and CE

## Pre-filter specifications

Surface media area	8.25m <sup>2</sup> approx (88.77 ft <sup>2</sup> )
Filter media	Borosilicate
Filter media construction	Maxi pleat
Housing	Cardboard
Filter efficiency	95% @ 0.9 microns

## Combined filter specifications

HEPA filter media	Maxi pleat
HEPA media construction	Pleated with glue bead spacers
Filter efficiency	99.997% @ 0.3 microns
Surface media area	3.5m <sup>2</sup> (37.66 ft <sup>2</sup> )
Treated activated carbon	12kgs (26.4 lbs)
Filter housing	Zintec mild steel

## Unit part numbers

Model	Arm size	Part number
FumeKART	100mm	L3324A
FumeKART	75mm	L3224A

## Unit option

Description	Feature	Arm size	Part number
FumeKART	VOC monitoring	100mm	L3324A0004
FumeKART	VOC monitoring	75mm	L3224A0004

## Replacement filters

Description	Part number
Pre-filter	A1030167
Combined filter	A1030166

## 75mm arm attachments

Description	Part number
75mm pen nozzle	A1060150
200mm metal funnel	A1020344
420 x 320mm clear hood	A1020384
385mm clear round hood	A1080136

## 100mm arm attachment

Description	Part number
350mm metal round hood	A1080146
500mm clear round hood	A1060152

## Hood attachments



75mm pen nozzle  
- 75mm arm  
attachment



200mm funnel -  
75mm arm  
attachment



420 x 320mm  
clear hood -  
75mm arm  
attachment



385mm clear  
round hood -  
75mm arm  
attachment



350mm metal  
round hood -  
100mm arm  
attachment



500mm clear  
round hood -  
100mm arm  
attachment

*Datasheet correct at time of publishing.*

*Where applicable, the carbon used in BOFA units is capable of removing a wide range of VOCs, however it is the responsibility of the user to ensure the carbon is suitable for their application. For specific applications, please contact us for details.*

**Important Notice:** *Many factors beyond the control of BOFA can affect the use and performance of BOFA products in a particular application, including the conditions under which the product is used. Since these factors are uniquely within the user's knowledge and control, it is essential the user evaluate the products to determine whether the product is fit for the particular purpose and suitable for the user's application. All products, product specifications, availability and data are subject to change without notice, and may vary by region or country.*

*Think before you print! Please consider the environment before printing this document.*

