

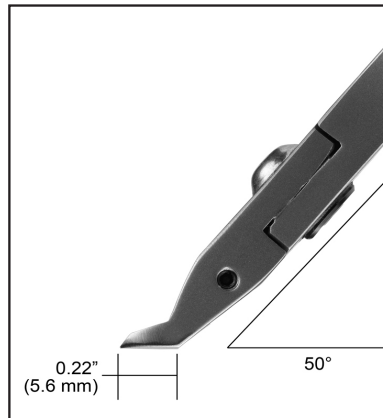

Features:

- **Application:** Cutting edges at an angle to the board are preferred when access to the object being cut is very limited or when the work area is very crowded. 7082 features a small cutting head with relief for excellent visibility. Offering durability combined with fine cutting.
- **Head Shape:** Angulated 50°, Small Oval Head
- **Material:** Carbon Steel
- **Material Hardness:** 62-63 HRC
- **Handle Grips:** Cushion Double Sheathed, ESD Safe
- **RTT Resistance:** $<1 \times 10^{11}$ ohms tested per ANSI/ESD STM11.13 Two-Point Probe, resistance measurement for static dissipative materials

Item	Cutting Edge	Cutting Capacity (Soft Copper Wire)	Angle	Handle Length	Overall Length
7082	Flush	.008 in - .030 in 0.1 mm - 0.8 mm 32 - 20 AWG	50°	Long Ergonomic	5.9 in 149 mm

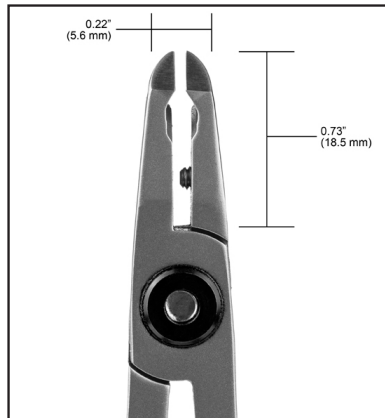

Unless otherwise noted, tolerance is $\pm 10\%$.

Specifications and procedures subject to change without notice.

SMALL ANGULATED 50° OVAL FLUSH CUTTER, LONG HANDLE

TRONEX

2860 CORDELIA RD, STE 230, FAIRFIELD, CA 94534
 PHONE: (909) 627-2453
 WEBSITE: TronexTools.com

DRAWING NUMBER
7082

DATE
June 2021