



A Donaldson Company

A WORLD LEADER IN FUME EXTRACTION TECHNOLOGY

FumeCAB 700

ELECTRONICS, PHARMACEUTICAL & MEDICAL

Last Updated on 30.08.2018



The complete solution for fume cabinet extraction for a broad range of applications.

Partial enclosures are becoming the recommended extraction option for a variety of applications.

The FumeCAB 700 integrated filtration system has a innovative Cam filter change design that enables safe and simple front loading filter replacement and provides many benefits over alternative rear access systems.

Ultra-bright slim line energy saving LED lights come as standard with optional UV lighting, making the FumeCAB 700 an ideal choice for applications such as the conformal coating of PCBs, where operators can now easily identify uniformity issues with the coating.

Technology



HEPA filter



Automatic flow control (AFC) technology (230v only)



Reverse flow air (RFA) technology



Advanced carbon filter (ACF) technology



ProTECT service plan



SureCHECK quality standard

Key features of the FumeCAB 700

Certified to BS 7989:2001 - Recirculatory filtration fume cabinet specification
Standard

Energy saving ultra-bright slim line LED lighting
Standard

Low noise level
Standard

Side entry blind grommets for equipment access
Standard

UV lighting
Optional

Stand
Optional

Auto Sensing Flow Control
Standard

Twin coated anti UV / anti splash protective Polycarbonate visor
Standard

Large working area
Standard

Audible and visual warning alarms
Standard

VOC monitor
Optional

Contact BOFA at <https://bofainternational.com/en/contact/>

<https://bofainternational.com/us/portal/datasheets/fumecab-700/>



Technical specification

1. Unit / Filter condition display - Automatic Flow Control

2. On / off switch

3. Filter compartment hinges

4. Cable entry grommet

5. Transparent visor

6. Transparent visor hinges

7. Power cable inlet

8. Internal LED lighting

9. Exhaust outlet

10. LED/UV light switch

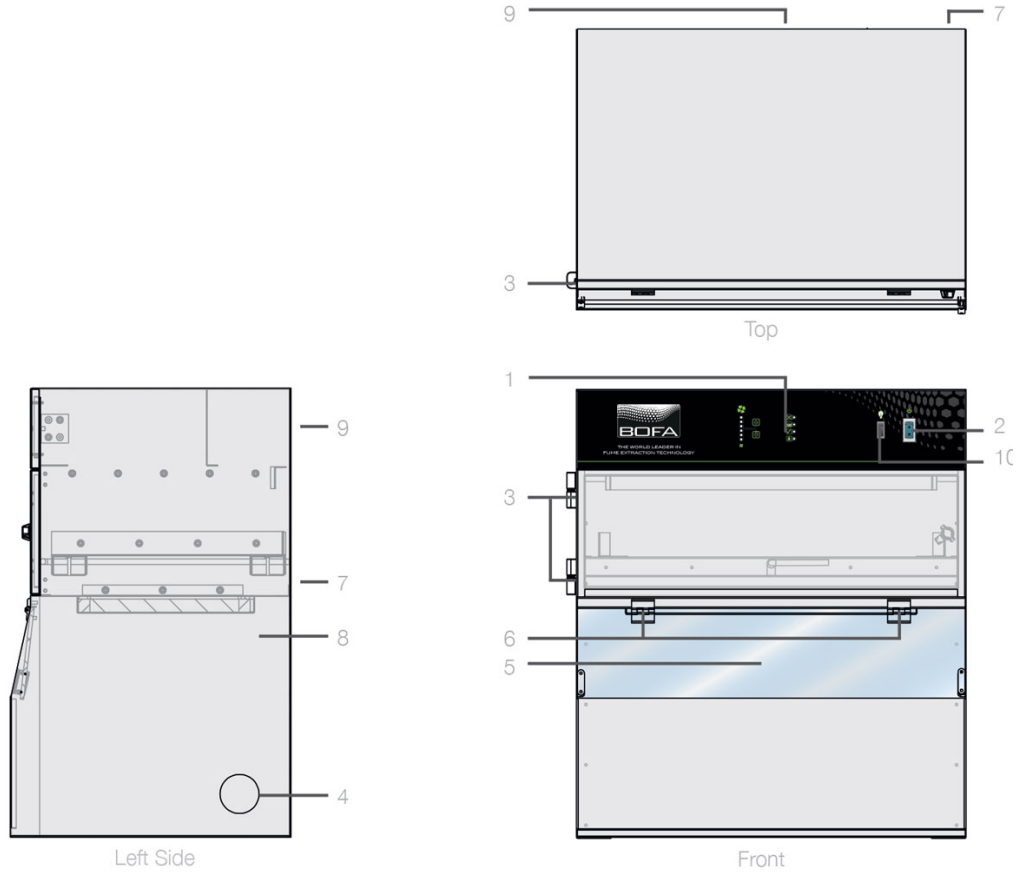

Airflow through filter

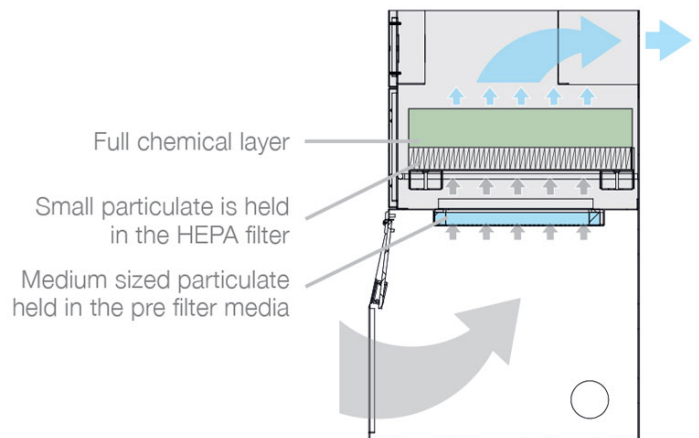
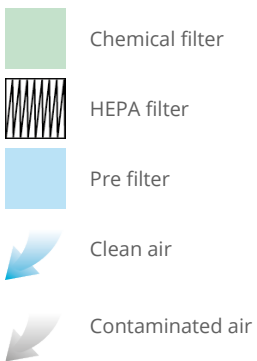

Technical data

Product	EU	US
Dimensions (HxWxD)	780 x 700 x 490 mm	(30.71 x 27.56 x 19.29")
Opening dimensions (h x w)	675 x 225mm (26 x 8.8")	675 x 225mm (26 x 8.8")
Cabinet construction	Powder coated mild steel	Powder coated mild steel

Technical data

Face velocity	0.4m/s (78.7ft/min)	0.5m/s (100ft/min)
Max face velocity	0.6m/s (118ft/min)	
Electrical data	230v 50/60Hz Full load current: 2 amps	115v 50/60Hz Full load current: 3 amps
Noise level	< 53dBA (at typical operating speed)	< 55dBA (at typical operating speed)
Weight	65kg	143lbs
Exhaust outlet (optional)	100mm	100mm
Approvals	CE	CE

Pre-filter specifications

Filter media construction	Filter pad
Filter housing	Cardboard
Filter efficiency	99% @ 0.3 microns

Combined HEPA / Gas filter specifications

Product	FumeCAB 700 Powder coated
HEPA filter media	Borosilicate
HEPA media construction	Pleated with glue bead spacers
Filter housing	Zintec mild steel
Treated activated carbon	10kgs (22 lbs)
Filter efficiency	99.997% @ 0.3 microns

Unit part numbers

Model	Voltage	Part no.	Optional UV lights	Optional VOC monitor	Optional stand
FumeCAB 700 Powder coated	230V	E2742A	A2009	A2003	A1060063
FumeCAB 700 Powder coated	115V	E2741A	A2009	A2003	A1060063

Replacement filter part numbers

Description	Part number
Pre-filter	A1030269
Combined filter	A1030270



Internal work area

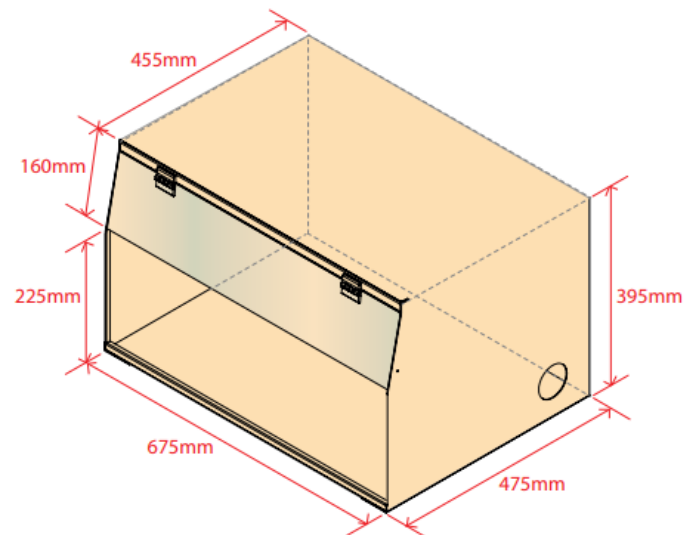

Optional stand



Optional stand specifications

Dimensions (HxWxD)

950 x 690 x 497mm / 37.4 x 27.16 x 19.56"

Stand construction

Powder coated mild steel

Datasheet correct at time of publishing.

Where applicable, the carbon used in BOFA units is capable of removing a wide range of VOC's, however it is the responsibility of the user to ensure the carbon is suitable for their application. For specific applications, please contact us for details.

Think before you print! Please consider the environment before printing this document.