

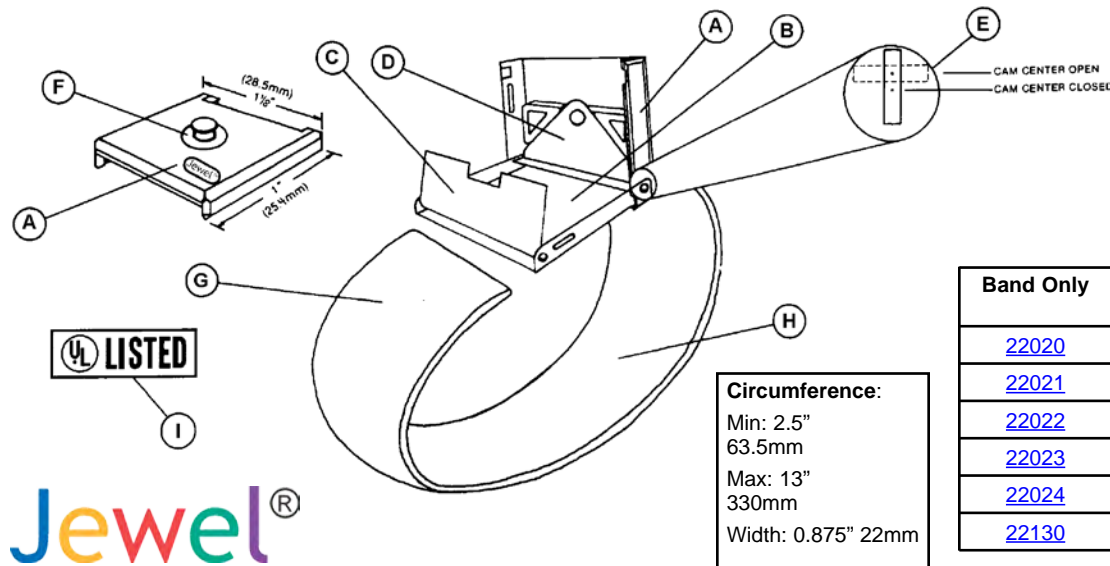

Made in America



- Jewel®**
- A. Insulating cap, ABS plastic. Jewel® logo molded into cap.
 - B. 300 series stainless steel backplate (0.016" thick). Manufacturing date code is stamped into stainless steel backplate.
 - C. Small cam lock, allows material replacement. 300 series stainless steel.
 - D. Large cam lock, allows size adjustment, maintains electrical continuity even when open. 300 series stainless steel.
 - E. Floating cam lock* allows wide opening for easy adjustment and secures material down against base plate when closed.
 - F. 4mm snap stud machined from 300 series stainless steel. Fits to 4mm spring loaded medical type socket. Coil cord disengages from snap with 1-5 lbs. of perpendicular force. Durable, providing long life well beyond that of sheet metal snaps.
 - G. Knit elastic band material of light blue fiber; .875" (22mm) wide and 0.10" (2.5mm) thick. 50 strands of textured polyester, 36 strands of lycra spandex and 14 strands of silver plated polypropylene yarn. Made with pure silver irreversibly bound to fibers providing both antimicrobial and anti-odor performance. Outer surface of grey fibers act as an insulator.

- H. The conductive silver plated polypropylene (see G) represents 13.5% of the material by weight. The 14 strands of conductive polypropylene are randomly knit on the inner surface of the material and are electrically isolated from the outer surface (grey side).
- I. Underwriters Laboratory listing 90P1C.

Thermoplastic elastomer strain relief molded on. Flex life average >50,000,000 cycles (per ESD S1.1 Bending Life Test, greatly exceeding the 16,000 average cycle requirement). Break load average 30 pounds.

Jewel® Wrist Bands and Coil Cords meet and exceed the Wrist Band and Wrist Cord requirements of ANSI/ESD S20.20 except that ESD S1.1 paragraph 5.9 states "Only wrist strap incorporating a nonstandard [resistor] value shall use the color red on any portion of the wrist strap."

Jewel® Lifetime Limited Warranty

ESD Systems.com expressly warrants that for a period of 1 year from the date of purchase, ESD Systems.com Jewel® Wrist Straps and Coil Cords will be free of defects in material (parts) and workmanship (labor). In addition, normal use will not cause Coil Cord resistor strain relief connection or Wrist Band 4 mm snap stud to wear sufficiently to open path-to-ground circuit. Within the lifetime warranty period, a credit for purchase of replacement ESD Systems.com Jewel® products, or, at ESD Systems.com's option, the ESD Systems.com Jewel® product will be repaired or replaced free of charge. If product credit is issued, the amount will be calculated based upon the original invoice purchase price.

See drawing [23550](#) for coil cord specifications.

Band Only	Band w/6' Coil Cord	Band w/10' Coil Cord	Band w/ 6' Right Angle Cord	Color
22020	22025	22030	22120	Sapphire
22021	22026	N/A	22121	Ruby
22022	22027	N/A	22122	Topaz
22023	22028	N/A	22123	Emerald
22024	22029	N/A	22124	Amethyst
22130	Elastic Replacement Strip			

Made in U.S.A. *U.S. Patent No. 4,662,695

JEWEL® WRISTBAND, ELASTIC, ADJUSTABLE

ESD SYSTEMS.com

ESD SYSTEMS.COM
 432 NORTHBORO ROAD CENTRAL
 MARLBORO, MA 01752 USA
 TEL. (508) 485-7390 FAX (508) 480-0257



Visit our online library of Tech Drawings:
<http://www.esdsystems.com>

DRAWING NUMBER:
 TD-22020

DATE
 August
 2009