

SEMTRONICS

ZVM1002

Continuous Dual Operator Zero Volt Monitoring™ System



INSTALLATION AND OPERATING INSTRUCTIONS

**For sales and Service in
North America contact:**
ESD Systems.com
ESDSystems.com
Sales@ESDSystems.com
Phone: 508-485-7390
Fax: 508-480-0257

Corporate Office:
3651 Walnut Avenue,
Chino, CA 91710
Phone: (909) 627-8178
Fax (909) 627-7449

**For sales and service in Europe and
Asia contact:**
OK International - European Headquarters
Eagle Close, Chandlers Ford,
Hampshire, SO53 4NF U.K. England
<http://www.okintl.com/location>
Tel: +44 (0)23 8048 9100
Fax: +44 (0)23 8048 9109

DESCRIPTION

The Semtronics ZVM1002 provides continuous ground monitoring of two operators and their workstations using patented ZERO VOLT MONITORING™ resistive loop technology. No other method is as direct and reliable. This technology allows the operator to typically be near zero volts with respect to Earth ground. The ZVM1002 is also unaffected by capacitance variations associated with personnel and environmental conditions.

Continuous Monitors pay for themselves improving quality, productivity, eliminating wrist strap daily testing and test result logging. Per ESD-S1.1 paragraph 6.1.3 Frequency of Functional Testing “The wrist strap system should be tested daily to ensure proper electrical value. Daily testing may be omitted if constant monitoring is used.” Per ESD Handbook TR 20.20 paragraph 5.3.2.4.4 “Typical Test programs recommend that wrist straps that are used daily should be tested daily. However, if the products that are being produced are of such value that knowledge of a continuous, reliable ground is needed, and then continuous monitoring should be considered or even required.”

ESD Handbook TR 20.20 paragraph 5.3.2.4.4 Test Frequency “Because wrist straps have a finite life, it is important to develop a test frequency that will guarantee integrity of the system. Typical test programs recommend that wrist straps that are used daily should be tested daily. However, if the products that are being produced are of such value that knowledge of a continuous, reliable ground is needed, and then continuous monitoring should be considered or even required.”

ESD TR1.0-01-01 section 1.0 Introduction

“Since people are one of the greatest sources of static electricity and ESD, proper grounding is paramount. One of the most common ways to ground people is with a wrist strap. Ensuring that wrist straps are functional and are connected to people and ground is a continuous task.”

THEORY OF OPERATION

ESD TR1.0-01-01 section 2.3 Resistance (or Dual Wire) constant monitors

“This type of monitor is used with a two wire (dual) wrist strap. When a person is wearing a wrist strap, the monitor observes the resistance of the loop, consisting of a wire, a person, a wristband, and a second wire. If any part of the loop should open (become disconnected or have out of limit resistance), the circuit will go into the alarm state.”

ESD TR1.0-01-01 section 2.3 Resistance (or Dual Wire) constant monitors

“A DC signal (current) travels through a wire to the first half of the wristband. Crossing the person’s skin, the signal enters the second half of the wristband, and returns through the second wire to the monitor. In this way, the resistance of the Wrist Strap System is measured. While the continuity of the loop is monitored, the connection of the wrist strap to ground is not monitored.”

ESD TR1.0-01-01 section 2.3 Resistance (or Dual Wire) constant monitors

“There are two types of signals used by resistance based constant monitors; steady state DC and pulsed DC. Pulsed DC signals were developed because of concerns about skin irritation caused by early steady state DC units. However, pulsed DC units introduce periods of off time (seconds) when the system is not being monitored.”

PACKAGING

- 1 Zero Volt Monitor™
- 1 Snap Kit
- 1 Plug-in Power Supply (110 VAC 60Hz or optional 220 VAC - 50 Hz input and 12 VDC 500 mA center pin positive output)
- 2 Wrist Strap Kits
- 2 Operator Ground Cables (black and white)
- 2 Mat Ground Cords (black and white)
- 3 Black Ground Cords (1 for Monitor, 2 for Mats)

INSTALLATION

- I. Remove the monitor from the carton and inspect for damage.
- II. Determine the mounting location of the ZVM1002 monitor. The front panel should be visible to both of the operators.
- III. Determine the mounting locations of the operator remotes. Make sure to place the remotes at a distance that enables its leads to reach the monitor.
- IV. Install the remotes to the workbench or another surface using the provided screws.

Note: The ZVM™ remotes are configured differently from other Semtronics remotes. Be sure to only use the remotes that were packaged with your ZVM™.

- V. Attach the tinned wire ends of the mat cords to their appropriate screw terminal block connection located at the rear of the unit (See Figure 1). The white cord is for OPERATOR 1 and the black cord is for OPERATOR 2.
- VI. Attach the work surface mats to ground using two of the three black ground cords (See Figure 2). Attach the ring terminal end of the cord to the bench common ground point or other appropriate ground point.
- VII. Attach the tinned wire end of the third black ground cord to the center position on the screw terminal block on the rear of the unit. Attach the ring terminal end to an alternate ground point. It is important that this ground wire is attached to a different ground point than the mat ground cord of the previous step. The face plate screw of a grounded AC wall outlet may provide a convenient connection point.
- VIII. Route the hard-wired black and white mat monitor cords from the back of the monitor to the ground mats. Attach the white mat ground wire to the OPERATOR 1 mat and the black mat ground wire to the OPERATOR 2 mat.
- IX. Insert the modular plugs of each remote cord into their appropriate modular jacks located at the rear of the unit (See Figures 1).
- X. Connect the DC power supply to the power jack located at the rear of the unit. Route the wire from the supply to a nearby AC outlet and plug the power supply into the outlet. Make sure the voltage and frequency match those listed on the power supply. The monitor is now powered.

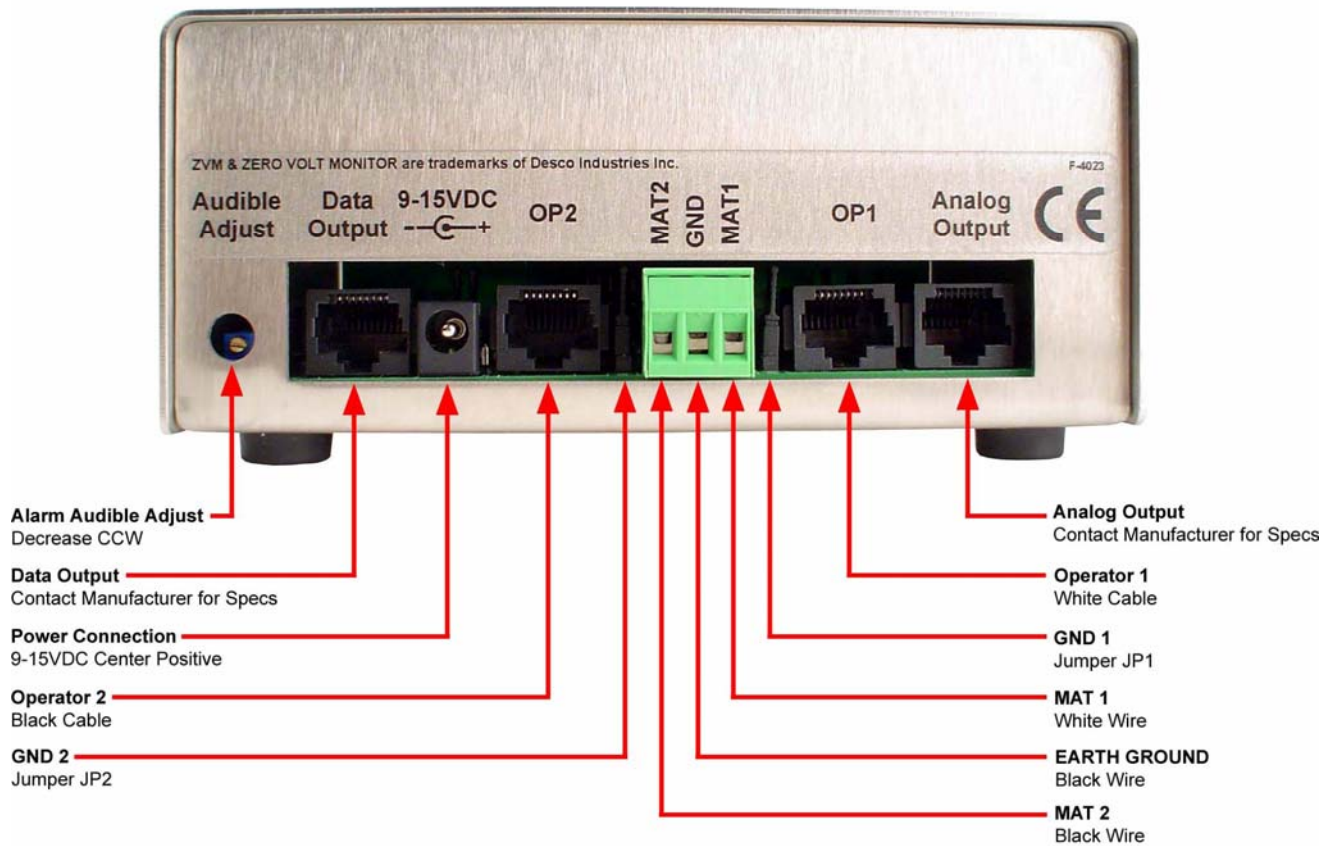

Figure 1. Rear View of the Zero Volt Monitor™

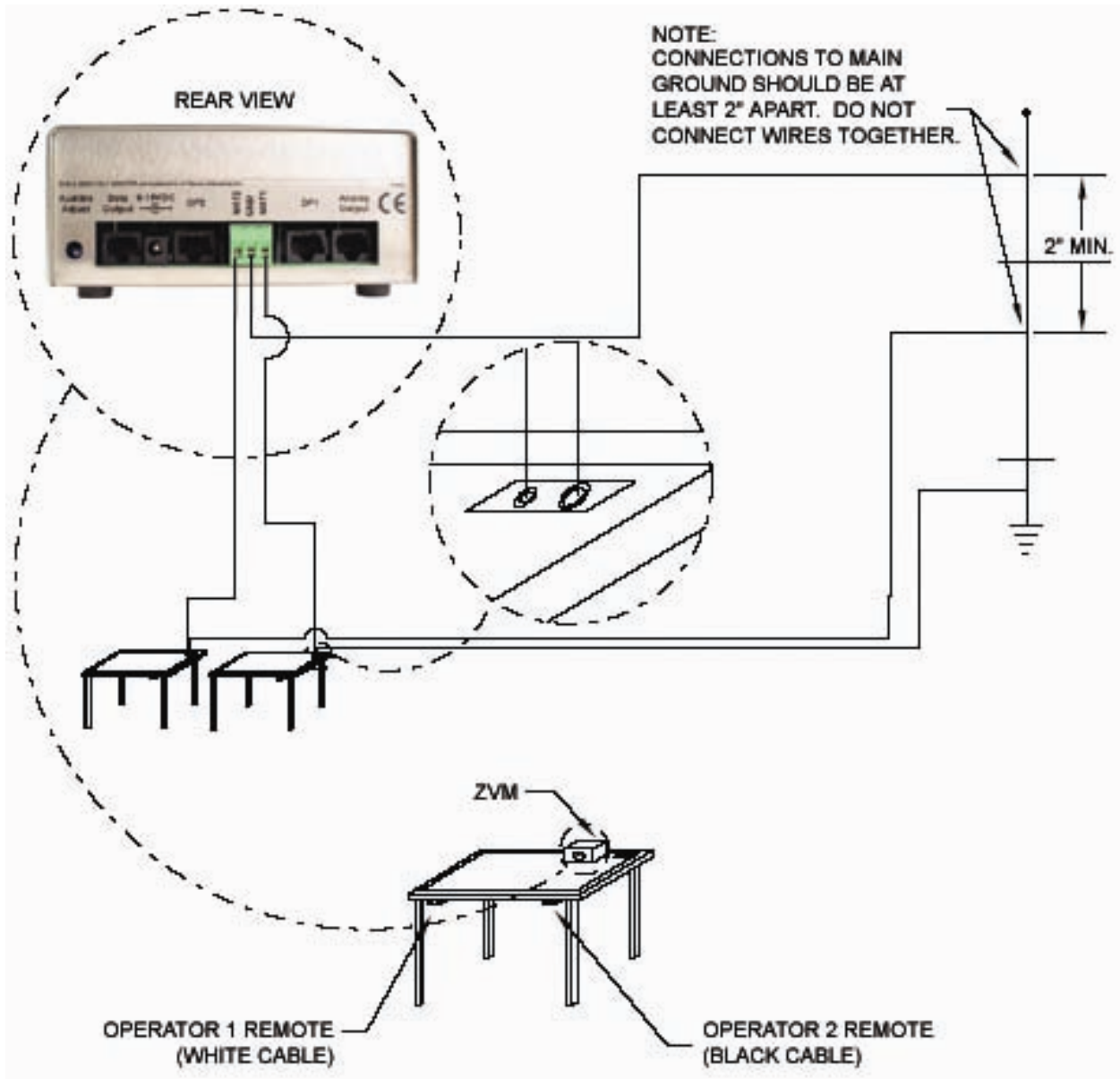

Figure 2. Installing the Zero Volt Monitor™

OPERATION

Once Installation steps I - X have been completed, the unit will be monitoring the mats' ground.

Then connect the operator wrist straps and wrist cords by connecting the dual snaps on the operator wrist cords to the wrist strap, and the mono plug at the other end of the wrist cord into the operator remote jack (See Figure 3). Monitoring of the operators will remain in the "STANDBY" position until an operator's wrist cord is plugged into the remote jack.

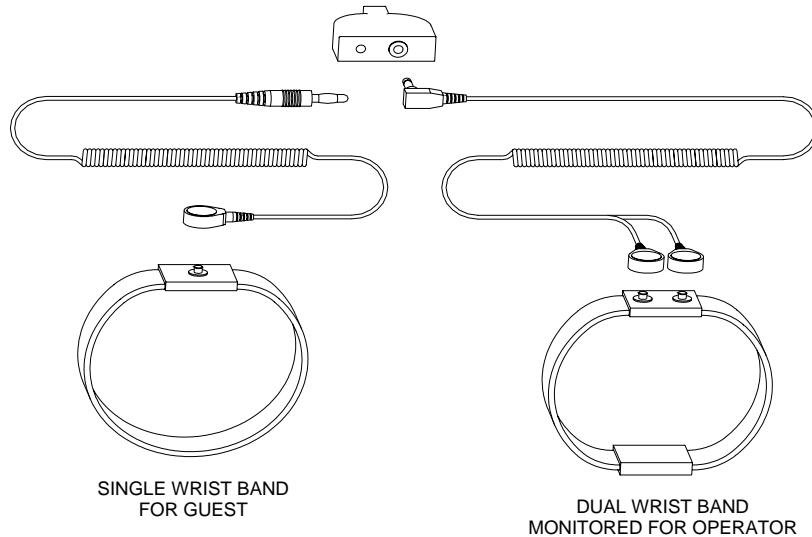

Figure 3. Connecting the Operator Wrist Straps and Wrist Cords

NOTE: The operator remote has two jacks.

The 3.5 mm mono jack is to be used for the dual wrist strap. A dual operator wrist cord plugged into this jack will be monitored.

The banana jack is grounded for use with a single conductor operator wrist cord. This is an unmonitored grounded guest hookup.

Charge Detection

When the operator is connected to the remote and accumulates a voltage greater than ± 1.25 volts, the CHARGE LED (red) will display in its respective OPERATOR section (for charge detection data out, see the Data Output section on Page 8). To disable charge detection on the display, shunt jumper JP6 inside the unit (See Page 7). If a charge is detected while using this configuration, the display will remain in its previous state until the charge is no longer detected.

Alarm Indicators

Repetitive Single Beep	OPERATOR 1 / GROUND 1 Fail
Repetitive Double Beep	OPERATOR 2 / GROUND 2 Fail
Continuous Alarm	OPERATOR 1 and OPERATOR 2 / GROUND 1 and GROUND 2 Fail

The alarm volume may be adjusted with the potentiometer located at the rear of the unit. Adjust the potentiometer counterclockwise to decrease the volume. The volume control may be disabled or enabled by the jumper JP5 inside the monitor (See Page 7 for more details).

Status Indicators

Standby condition:	Operator not plugged into the remote. Indicated by the blue LED in the OPERATOR section of the display
Operator Fail High*:	Operator plugged into the remote and the series resistance is greater than or equal to 10.4M ohms (3.1M ohms operator to ground). Indicated by the red LED in the OPERATOR section of the display as well as an audible alarm
Operator Pass Safe*+:	Operator plugged into the remote and the series resistance is within the range of 1.9M ohms (975k ohms operator to ground) to 10.0M ohms (3.0M ohms operator to ground). Indicated by the green LED in the OPERATOR section of the display
Operator Fail Low*:	Operator plugged into the remote and the series resistance is less than or equal to 1.70M ohms (925k ohms operator to ground). Indicated by the yellow LED in the OPERATOR section of the display as well as an audible alarm
Ground Fail High*:	The series resistance from the mat connection to ground and back to the circuit is greater than 3.8M ohms or 3 ohms (depending on the configuration). Indicated by the red LED in the GROUND section of the display as well as an audible alarm
Ground Pass Safe:	The series resistance from the Mat connection to ground and back to the circuit is less than 3.5M ohms or 2 ohms (depending on the configuration). Indicated by the green LED in the GROUND section of the display

* The resistances quoted above are the Factory Defaults. These numbers will vary depending on the configuration.

+ The Ground monitoring circuit not only monitors your workstation ground, but ensures a correct ground for the operator. Therefore, if **both** grounds are in the HIGH mode, your operators may not be properly grounded.

JUMPER SETTINGS

Audible Adjust Disable (Jumper JP5)

- I. Remove the cover from the case.
- II. Remove jumper JP5 (See Figure 4) to enable the Audible Adjust Potentiometer located at the rear of unit, or add the jumper to disable it (maximum volume).

Charge Display Disable (Jumper JP6)

- I. Remove the cover from the case.
- II. Remove jumper JP6 (See Figure 4) to enable the Charge LED located on the front of the unit, or add the jumper to disable the Charge LED.

Data Out with Charge (Jumper JP7)

- I. Remove the cover from the case.
- II. Remove jumper JP7 (See Figure 4) to disable the Charge Data Output for data collection, or add the jumper to enable the Data Output.

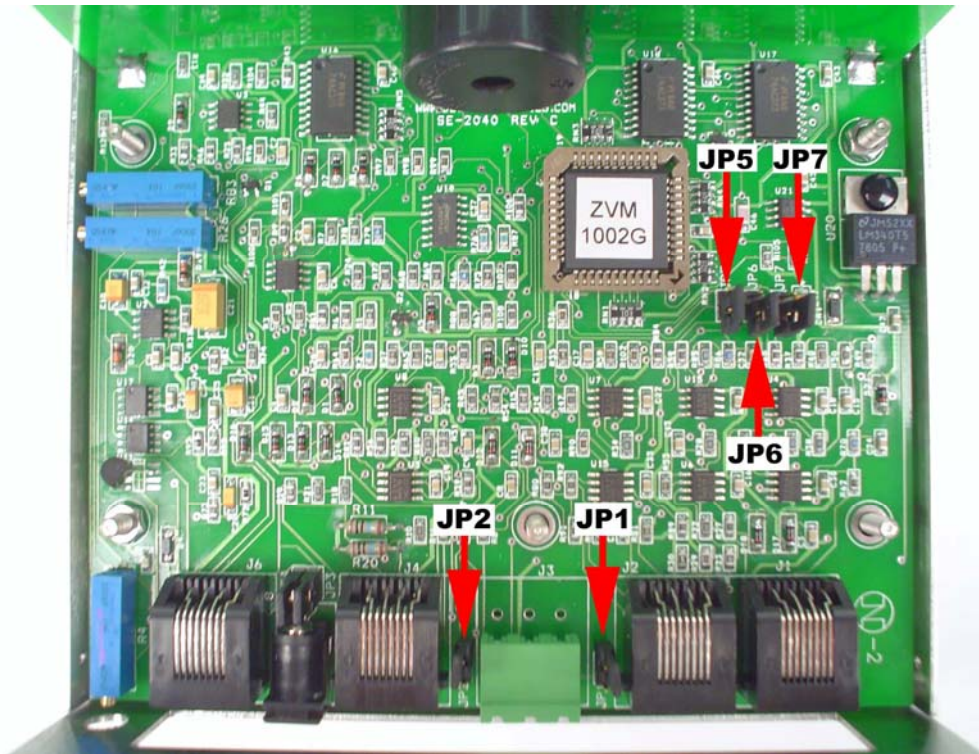

Figure 4. Jumpers JP1, JP2, JP5, JP6, JP7

SPECIFICATIONS

Data Output

The ZVM1002 has a data output on the rear of the unit for operator and mat status. Jumper JP7, located inside the unit, enables charge detection operator status to be sent out instead of operator low status. To enable charge detection data output, shunt the jumper and choose "ZVM Charge Detection Enabled" as the device for this ZVM1002. In this configuration an operator "FAIL LOW" will be sent out as a "PASS.". Contact the manufacturer for additional information on the Data Output.

DIMENSIONS

Zero Volt Monitor™	5.62" x 4.85" x 2.40"
Operator Ground Cables	Length: 12'
Black Ground Cords	Length: 10'

CALIBRATION AND ADJUSTMENTS

CALIBRATION

The ZVM1002 can be calibrated with the 62170 Limit Comparator. This will allow you to set the operator series resistance pass high and low limits. The factory default settings are 10M ohms high and 1.9M ohms low. Refer to the 62170 Limit Comparator instruction manual for more information

NOTE: The series "test" resistance is not the same as the operator to ground resistance. As shown in the figure below, the series resistance is made up of the 1M ohm resistors in the cord, the wrist band to operator's skin resistance (skin contact resistance), and the operator's resistance (human body resistance).

For a given series resistance, the typical operator to ground resistance can be calculated from the following formula.

$$R_{\text{operator to ground}} = (R_{\text{series}} + 2\text{M ohms}) / 4$$

For a given operator to ground resistance, the series resistance can be calculated from the following formula.

$$R_{\text{series}} = (R_{\text{operator to ground}} * 4) - 2\text{M ohms}$$

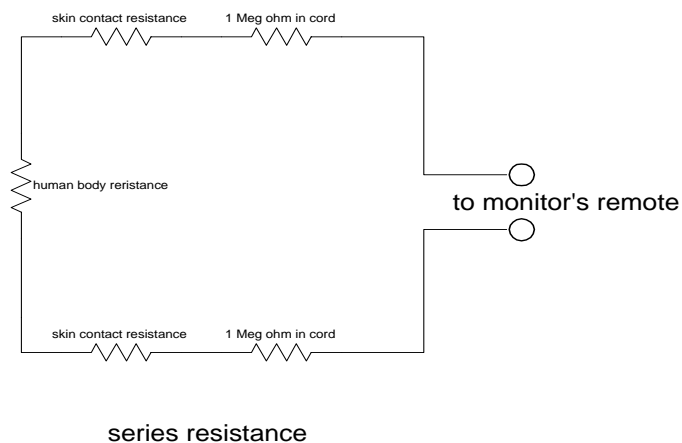

MAT RESISTANCE SETTINGS

3.5M ohm

- I. If the desired resistance is 3.5M ohms, jumpers JP1 (GND 1) and JP2 (GND 2), located at the rear of the unit, (See Figure 1) need to be on one pin.
- II. The associated potentiometers need to be adjusted fully clockwise. The pots are located inside the unit on the bottom board. The potentiometer closest to the rear of the unit is for GND 1 and the one closest to the front of the unit is for GND 2 (See Figure 5).

High Resistance (10k ohms to 3.5M ohms)

- I. If the desired resistance is high (10k ohms – 3.5M ohms), jumpers JP1 (GND 1) and JP2 (GND 2), located at the rear of the unit, (See Figure 1) need to be on one pin.
- II. Next, the desired resistance needs to be added in between the ground terminal and ground. Use a resistor sub box to accomplish this task.
- III. Connect the mat wire to the sub box and connect the sub box to ground.
- IV. Increase the resistance on the sub box to the desired level.
- V. Turn the appropriate pot (See Figure 5) counterclockwise until the GROUND FAIL (red LED).
- VI. Slowly turn the pot clockwise until the GROUND passes (green LED).
- VII. Add 10% more resistance (at least 1 ohm) to the resistance and see if the GROUND FAIL LED (red) turns on.
- VIII. Return back to the starting resistance and confirm that the green LED turns back on.

NOTE: If the unit does not go red with added resistance or return back to green when the extra resistance is removed, repeat steps V - VIII with added care in turning the pot.

Low Resistance (< 1k ohms)

- I. If the desired resistance is low (< 1k ohms), jumpers JP1 (GND 1) and JP2 (GND 2), located at the rear of the unit, (See Figure 1) need to be on both pins.
- II. Next, the desired resistance needs to be added in between the ground terminal and ground. Use a resistor sub box to accomplish this task.
- III. Connect the mat wire to the sub box and connect the sub box to ground.
- IV. Increase the resistance on the sub box to the desired level.
- V. Turn the appropriate pot (See Figure 5) counterclockwise until the GROUND FAILS (red LED).
- VI. Slowly turn the pot clockwise until the GROUND passes (green LED).
- VII. Add 10% more resistance (at least 1 ohm) to the resistance and see if the GROUND FAIL LED (red) turns on.
- VIII. Return back to the starting resistance and confirm that the green LED turns back on.

NOTE: If the unit does not go red with added resistance or return back to green when the extra resistance is removed, repeat steps V - VIII with added care in turning the pot.

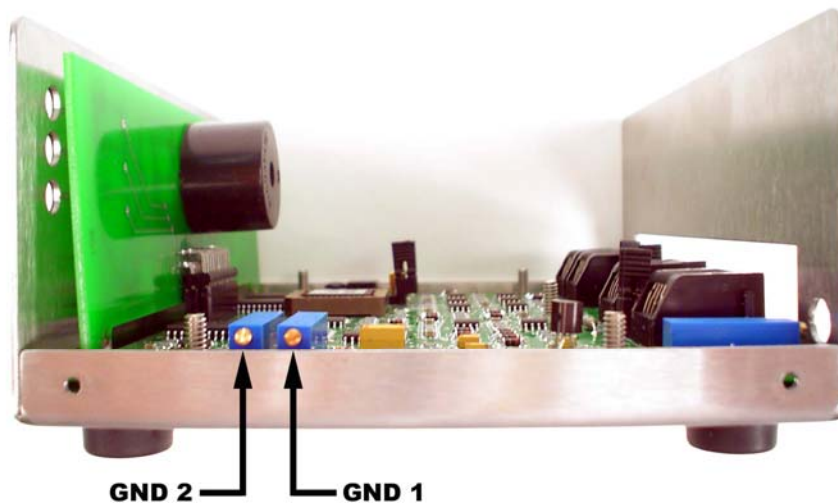

Figure 5. GND 1 and GND 2 Potentiometers

CONTACT AND WARRANTY

USA

Semtronics
3651 Walnut Ave.
Chino, CA 91710
Tel: (909) 627-8178
Fax: (909) 627-7449

LIMITED WARRANTY

Semtronics expressly warrants that for a period of one (1) year from the date of purchase, Semtronics ZVM1002 will be free of defects in material (parts) and workmanship (labor). Within the warranty period, a unit will be tested, repaired, or replaced at our option, free of charge. Call Customer Service at 909-627-8178 (Chino, CA) or 781-821-8370 (Canton, MA) for Return Material Authorization (RMA) and proper shipping instructions and address. Include a copy of your original packing slip, invoice, or other proof of date of purchase. Any unit under warranty should be shipped prepaid to the Semtronics factory. Warranty replacements will take approximately two weeks.

If your unit is out of warranty, Semtronics will quote repair charges necessary to bring your unit up to factory standards. Call Customer Service at 909-627-8178 for proper shipping instructions and address. Ship your unit freight prepaid.

WARRANTY EXCLUSIONS

THE FOREGOING EXPRESS WARRANTY IS MADE IN LIEU OF ALL OTHER PRODUCT WARRANTIES, EXPRESSED AND IMPLIED, INCLUDING MERCHANTABILITY AND FITNESS FOR A PARTICULAR PURPOSE WHICH ARE SPECIFICALLY DISCLAIMED. The express warranty will not apply to defects or damage due to accidents, neglect, misuse, alterations, operator error, or failure to properly maintain, clean or repair products.

LIMIT OF LIABILITY

In no event will Semtronics or any seller be responsible or liable for any injury, loss or damage, direct or consequential, arising out of the use of or the inability to use the product. Before using, users shall determine the suitability of the product for their intended use, and users assume all risk and liability whatsoever in connection therewith.