

Dual Operator Workstation Continuous Monitor with Satellites - Operation, Installation and Maintenance



Made in America



Figure 1. ESD Systems.com # [41221](#) Dual Operator Continuous Monitor with Satellites

Description

Leading companies use continuous monitors as a cost effective component in satisfying the section 7.3 Compliance Verification Plan requirements of ANSI/ESD S20.20. The ESD Systems.com Dual Operator Continuous Monitor with Satellites continuously monitors the grounding integrity of:

- Two operators wearing wrist straps, and
- Two ESD worksurfaces' path to ground*

***Note:** Worksurface must have a conductive layer such as Dual Layer Rubber or Dissipative 3-Layer Vinyl or Micastat® Dissipative Laminate with conductive buried layers. Desco Continuous Monitors are not recommended for use with homogeneous matting.

The monitor will provide instantaneous notification of static control equipment failures, and eliminates the need of costly and difficult to supervise wrist strap logging record keeping. This unit is highly cost effective as it is designed to monitor any conventional single-wire wrist strap and ground cord system.

Per ESD Handbook ESD TR20.20 section 5.3.2.4.4 Test Frequency, "Because wrist straps have a finite life, it is important to develop a test frequency that will guarantee integrity of the system. Typical test programs recommend that wrist straps that are used daily should be tested daily. However, if the products that are being produced are of such value that knowledge of a continuous, reliable ground is needed, then continuous monitoring should be considered or even required."

The Dual Operator Continuous Monitor with Satellites is an impedance sensing device designed to monitor body types from a 5th percentile female to a 95th percentile male. This range covers a 5 foot tall 90 pound person to a 6 foot

5 inch 250 pound person in any production environment.* The [41221](#) is powered by a 120 VAC, 60/50 Hz, plug-in transformer which also provides connection to ground.

If the unit detects that the elements are outside industry standards, the continuous monitor will alarm, both an audible signal notifying the user of a problem and illuminating a red LED. Each Satellite Remote has an additional wrist strap ground point banana jack for a second user or supervisor, however, these grounds are not monitored.

ADVANTAGES OF CONTINUOUS MONITORING OVER PERIODIC TESTING

Many customers are eliminating periodic touch testing of wrist straps and are utilizing continuous monitoring to better ensure that their products were manufactured in an ESD protected environment. Full time continuous monitoring is superior to periodic or pulsed testing, and can save a significant amount of money in testing costs and rejected product. Periodic testing detects wrist strap failures after ESD susceptible products have been manufactured. The costs of dealing with the resulting catastrophic failures or latent defects can be considerable. Dual Operator Workstation Continuous Monitors eliminate the need for users to test wrist straps and log the results; by their function, these monitors satisfy the ISO and ANSI/ESD S20.20 test logging requirement. ANSI/ESD S20.20 section 7.3 states "Compliance verification records shall be established and maintained to provide evidence of conformity to the technical requirements." Per ANSI/ESD S1.1 Annex A.3 "Daily (wrist strap system) testing may be omitted if constant monitoring is used."

WAVE DISTORTION DETECTION TECHNOLOGY PROVIDES TRUE 100% CONTINUOUS MONITORING

ESD Systems.com designs and manufactures many of its Continuous Monitor product offerings using wave distortion technology. Wave distortion circuitry monitors current/voltage phase shifts and provides true 100% continuous monitoring. Electrical current will lead voltage at various points due to the combinations of resistance and capacitive reactance. By monitoring these "distortions" or phase shifts, the wave distortion Workstation Continuous Monitor will reliably determine if the circuit is complete.

*NASA Publication 1024-Anthropomorphic Source Book Volume 1: "Anthropometry for Designers"

** Per ANSI/ESD S20.20 paragraph 6.0.3. Tailoring "This document, or portions thereof, may not apply to all applications. Tailoring is accomplished by evaluating the applicability of each requirement for the specific application. Upon completion of the evaluation, requirements may be added, modified or deleted. Tailoring decisions, including rationale, shall be documented in the ESD Control Program Plan."

This is an Impedance type monitor. Per ESD TR12-01 section 2.2 Impedance (or single wire) constant monitors "The capacitance type of monitor is also known as an impedance monitor. They both work on the same theory, however the impedance monitor uses a detection circuit designed to reduce false alarms and eliminate adjustments. 'Single Wire' or 'impedance type' monitors use the phase difference between current and voltage to detect changes in impedance of the cord, band and person. A very low AC voltage is used for constant sensing. Any standard wristband and coiled cord can be used."

Wave distortion technology can be referred to as "vector impedance monitoring". This description is valid as the wave distortion technology measures the impedance at the monitored banana jack and looks for changes in either the capacitance or resistance of the circuit which includes the wrist strap and its wearer. It uses filtering and time domain sampling to filter out false signals caused by voltage offsets, 60 Hz fields and other electro-magnetic and electrostatic interference.

In normal factory environments, and with persons whose capacitance with respect to ground is within design limits (5 feet tall 90 pound person to 6 foot 5 inch 250 pound person), the Dual Operator Workstation Continuous Monitor cannot be "fooled". It will provide a reliable alarm only when the wrist strap or worksurface becomes dysfunctional or unsafe according to accepted industry standards. The Dual Operator Workstation Continuous Monitor is drift-free and designed to be insensitive to the effects of squeezing or stretching the coil cord.

ADVANTAGES OF WAVE DISTORTION AND SINGLE-WIRE TECHNOLOGY

The ESD Systems.com Dual Operator Workstation Continuous Monitor allows the use of any standard, single-wire wrist strap and coil cord. The monitor/wrist strap/cord system life-cycle costs are by far lower than alternative systems which require dual-wire cords and special wrist straps. Dual-wire cords are expensive and are the weak link of the system. They are the most likely component to need replacement. Over a five year period this can make a dual-wire system three times as expensive as a system utilizing single-wire wrist straps and cords.

The dictionary defines constant as uniform and unchanging, and continuous as uninterrupted. Nonetheless, some dual-wire resistance monitors utilize a pulsed test current and do not really provide continuous monitoring. For example, during each 2.2 second pulse cycle of a leading "constant" resistive monitor, electrical current is pulsed for only 0.2 seconds followed by an unmonitored interval of 2 seconds. This leaves the user/wrist strap unmonitored for over 90% of each cycle. Damaging ESD events can easily occur in the portion of the time in between the pulses. The off period of 2 seconds equals 2 billion nanoseconds, and "it takes only about 25 volts applied for 100 nanoseconds to blow most memories or microprocessor."* ESDSystems.com single-wire wrist straps meet all the requirements of ANSI/ESD S1.1. ESDSystems.com dual-wire resistance

continuous monitors do not use a pulsed test current; rather a low steady state test is used.

By using the reliable wave distortion technology to determine if the circuit is complete, there are no false alarms. There is no need to adjust or tune the monitor to a specific user or installation. The miniscule amount of electrical current (less than 1 volt coil cord signal) required to generate the waveform has never caused reported skin irritation and is extremely safe for use in voltage sensitive applications such as disk drive manufacturing.

Installation

Confirm that worksurface(s) is 1×10^7 ohms or less and has a conductive layer. Remove the monitor from its packaging and inspect for any shipping damage. Included with each Dual Operator and Dual Workstation Continuous Monitor should be:

- 1 Monitor Control unit
- 2 Satellite remote monitors with 6 mounting screws ([41301](#))
- 2 7ft. remote cables for connection to satellites
- 1 120 VAC transformer
- 2 6' Work surface ground cord with additional ring terminals
- 2 6' Ground cord
- 4 Push and clinch snap ([12102](#))
- 4 Counter Sink Washers
- 1 Certificate of Calibration

The Model [41221](#) monitor control unit is normally installed under the bench top toward the front edge of a workstation where the LEDs are easily visible. The unit is designed to be mounted using the flanges (See Figure 2).



Figure 2. Mounting the monitor

Figure 3 shows the monitor as it is viewed from the front.

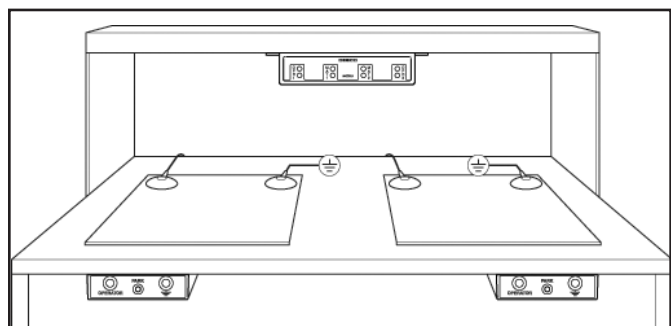

Figure 3. Operating the [41221](#) monitor

SATELLITE REMOTE MONITORS.

The Satellite remote monitors can be installed up to 7 feet away from the monitor control unit. Two operators plus two worksurfaces can be monitored at separate adjacent workstation mat circuit maybe bypassed by a switch located at the rear of the satellite. The satellite remote monitors are available separately as item [41301](#). Also shown on each satellite remote unit is a supervisor ground connection jack where a supervisor, guest, or equipment can be grounded.



Figure 4 shows the monitor control unit as it is viewed from the rear, with the work surface wiring in place.

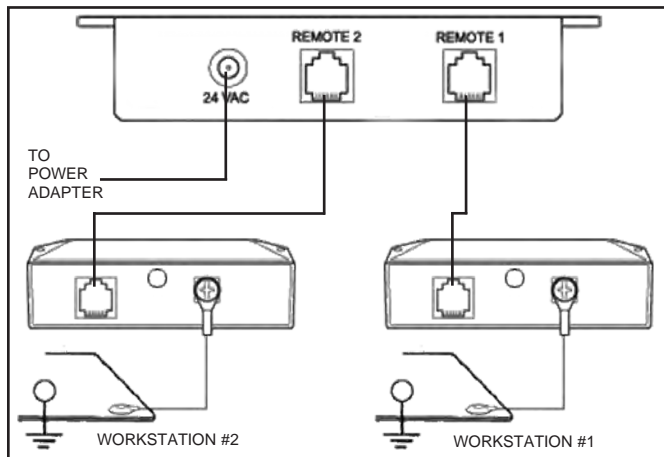

Figure 4. Wiring connection instructions for the [41221](#) monitor control unit.

The following procedure will outline how to correctly wire the [41221](#) monitor control unit to properly monitor an ESD protected workstation.

1. Use the rear phone jack connections and connect the Satellite Remote Units to the base unit with the phone cables. See Figure 4 for wiring connection instructions.
2. Mat monitoring may be bypassed by using the switch located inside a 1/4" hole at the rear of the satellite.
3. Verify that a ground cord is properly connected to snap socket on one corner of the ESD worksurface. The other end of the ground cord is to be attached to the workbench common point ground. After Satellite Remote Units are mounted, route wires using a direct route; try to avoid running wires adjacent to metal.
4. Confirm that worksurface surface resistance is 1×10^7 ohms or less. Connect the ring terminal end of the worksurface cord included with the unit to the screw on the back of the satellite. Snap the other end to the worksurface grounding point as shown in Figures 4 and 5.

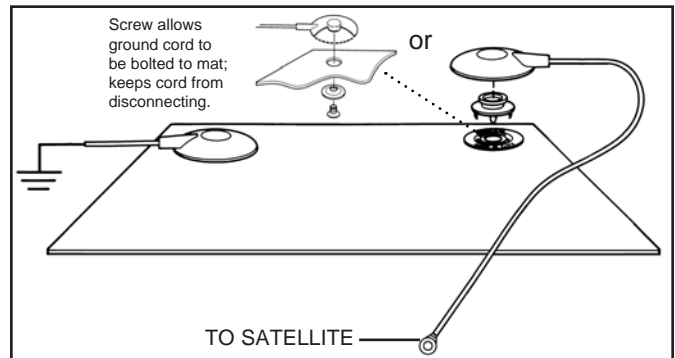

Figure 5. Installing cords on the worksurface.

5. A convenient 3-wire 120 VAC outlet should be located and tested for proper wiring and grounding. We recommend ESD Systems.com Item [94380](#) AC Outlet Analyzer to verify proper wiring.

6. Plug the transformer into the outlet and connect the plug into the back side of the monitor control unit. The green Work Surface LED should be lit. The monitor control unit is now ready for use. If the red Work Surface LED is flashing, check the snap fastener and ground cords for proper connection.

Installation on Micastat® Laminate

Materials Needed:

- 2 Flush Mount Ground Laminate Inserts
- 1 Installation Tool for Flush Mount Insert

1. Install the Flush Mount Inserts first. It is recommended to install one in the right back corner and the other in the left back corner of the Micastat® laminated bench top.
2. Once both inserts are installed, cut the ground cord supplied with the monitor into two pieces; make sure that the tinned end is long enough to connect from the worksurface terminal on the Satellite Remote Unit to one of the flush mount terminals located under the bench.
3. The remaining wire can then be used to connect the other flush mount terminal to ground using the supplied ring terminal. The shrouded molded end can then be cut off.

When complete, one flush mount terminal will connect the Micastat® laminate to ground while the other will connect it to a satellite remote unit. The satellite remote unit then monitors the ground connection between the two inserts, and since Micastat® is the only ESD laminate made with a physical uniform ground layer, it will monitor the entire Micastat® surface ground. The wires will stay under the bench, maximizing the usable space on the bench top.

Operation

When the satellite remote unit is installed and is connected to a grounded ESD protective work surface, the monitor's green Work Surfaces LED's and its two red Operator LED's should be on. The monitor takes 6 seconds to activate its alarm circuitry when it is first plugged in.

To use the monitor:

1. Plug a wrist strap cord, into either of the Satellite remote units marked "OPERATOR" on the front of the Satellite remote unit. This automatically activates the selected operator channel. The red Operator LED should turn on and the audio alarm should beep.

2. Remove the charges from your body by making contact with a properly grounded ESD worksurface. Snap the cord to the wristband, which should fit snugly on your wrist. This should silence the alarm and cause the LEDs to switch from red to green. If this does not happen, check the coil cord for continuity or damage. Examine your wristband and ensure that it has a secure fit. If you have dry skin use our ESD hand lotion, Item [35660](#) Reztore™ ESD Hand Lotion. When leaving the area a person can take the coil cord along or unplug the cord from wristband and attach the socket to the Satellite remote unit snap that is labeled "Park". This will de-activate the alarm and allow you to leave the station. If the cord is plugged into the jack marked "Operator" the monitor will alarm continuously until you either park the cord, or remove the cord from the operator jack. In the case of removing the cord from the jack, the audio alarm will only sound for approximately eight seconds.

Whenever the coil cord is accidentally withdrawn from the jack, or if continuity from the user to the satellite remote unit is not maintained, the alarm sounds, the green Operator LED turns off and the red Operator LED turns on.

Work Surface Channel

The [41221](#) Work Surface monitoring circuitry is sufficiently sensitive to detect extremely low current, allowing it to be used with mats having a resistance of up to 1×10^7 ohms (10 megohms). If user desire not to monitor worksurface, mat circuit can be bypassed with switch, located at the rear of the satellite.

When the monitor is connected to a static dissipative work surface, the amount of current that flows is a function of the total resistance between the monitor and through the work surface to ground. When the resistance of the work surface is below a present threshold, the monitor will indicate good. Conversely, if the resistance level is high when compared to the monitor's reference, the unit will alarm. This is an integrating resistance measuring circuit. Therefore, it is relatively insensitive to externally induced electromagnetic fields. The resistance threshold is factory set to 10 megohms (1×10^7 ohms). Custom worksurface range available upon request. Call for details.

Note: Per ESD S6.1, Grounding paragraph 4.1.1 "Every element to be grounded at an ESD protected station shall be connected to the same common point ground." The ESD control plan should include a tailoring** statement that continuous monitors are used and that consistent with manufacturer's design grounding is via AC adapter cord to equipment ground.

Specifications

Test range of monitored circuit	500K - 10M ohm [†]
Supervisor Jack	
Resistance to Ground	47k ohms typical
Work Surface Limit*	Set to 10 Megohms (1×10^7 ohms)
Operating Voltage	120 VAC, 50-60 Hz
Wrist strap open circuit voltage	1.2 volts peak to peak @ 1-2 MicroAmps
Mat test open circuit voltage	5 to 7.5 volts
Response time to alarm	< 50 mS
Operating Temperature	0 - 40°C
Long Term Drift	<0.5% per Decade (1st Decade is 1 hr)

Note: Work surface must have a conductive layer such as Dual Layer Rubber or Dissipative 3-Layer Vinyl or Micastat® Dissipative Laminate with conductive buried layers. ESD Systems.com Continuous Monitors are not recommended for use with homogeneous matting.

Maintenance and Calibration

The Dual Operator Workstation Continuous Monitor is solid state and designed to be maintenance free. The [41221](#) is calibrated to NIST traceable standards. There are no user adjustments that can be made. Because of the impedance sensing nature of the test circuit, special equipment is required for calibration. We recommend using the EMIT [50512](#) Continuous Monitor Calibration Unit whenever calibration is performed annually or any of the satellite remotes are replaced. The Calibration Unit is a most important product which allows the customer to perform NIST traceable calibration on continuous monitors and can be used to fulfill ANSI/ESD S20.20 Paragraph 6.2.2.2 Personnel Grounding Guidance, "Personnel should check constant monitoring devices (when used) to ensure that they are functional and operating before ESDS products are handled. In addition, constant monitoring devices should be functionally checked periodically to ensure that they are operating as designed." The EMIT [50512](#) is designed to be used on the shop floor at the workstation, virtually eliminating downtime, verifying that the continuous monitor is operating within tolerances.

[†] This cannot be verified with standard DC test equipment. The continuous monitor is an impedance sensing device and the limits are determined by the magnitude and angle of the impedance.

*Contact factory for special limits.

Limited Warranty

ESD Systems.com expressly warrants that for a period of one (1) year from the date of purchase, our Continuous Monitors will be free of defects in material (parts) and workmanship (labor). Within the warranty period, a unit will be tested, repaired or replaced at our option, free of charge. Call Customer Service at 508-485-7390 for a Return Material Authorization (RMA) and proper shipping instructions and address. You should include a copy of your original packing slip, invoice, or other proof of purchase date. Any unit under warranty should be shipped, prepaid to the ESD Systems.com factory. Warranty repairs will take approximately two weeks.

If your unit is out of warranty, ESD Systems.com will quote repair charges necessary to bring your unit to factory standards. Call Customer Service at 508-485-7390 for a Return Material Authorization (RMA) and proper shipping instructions and address.

Warranty Exclusions

THE FOREGOING EXPRESS WARRANTY IS MADE IN LIEU OF ALL OTHER PRODUCT WARRANTIES, EXPRESSED AND IMPLIED, INCLUDING MERCHANTABILITY AND FITNESS FOR A PARTICULAR PURPOSE WHICH ARE SPECIFICALLY DISCLAIMED. The express warranty will not apply to defects or damage due to accidents, neglect, misuse, alterations, operator error, or failure to properly maintain, clean or repair products.

Limit of Liability

In no event will ESD Systems.com or any seller be responsible or liable for any injury, loss or damage, direct or consequential, arising out of the use of or the inability to use the product. Before using, users shall determine the suitability of the product for their intended use, and users assume all risk and liability whatsoever in connection therewith.